



SCAN HELICOPTER POWER TROWEL

MANUAL



SCANMASKIN
MACHINES—MINERALS—KNOW-HOW

Dear Customer!

Thank you for choosing Scanmaskin as your supplier.
We wish you all the best with your new "Scan Helicopter" and hope that it lives up to your expectations.

Scanmaskin Sweden AB



Claes-Göran Bergstrand
Managing Director

Address:
Scanmaskin Sweden AB
Box 187
SE-437 22 Lindome / Gothenburg
Sweden
Telephone: +46 (0) 31 99 49 70
Fax: +46 (0) 31 99 48 70
www.scanmaskin.com

Swedish Patent No: 503636
International patent application No: PTC/SE96/00751

Important Information!

This User Guide only concerns the power trowel machine "**Scan Helicopter**".
The Scan Helicopter may only be used for horizontal surfaces approved by Scanmaskin Sweden AB.

If the Scan Helicopter is used for other purposes or handled in ways other than that described in this User Guide, Scanmaskin Sweden AB disclaims all responsibility.

Especially note the section "**2 Safety Regulations**". Read the User Guide before using the Scan Helicopter machine. Scanmaskin Sweden AB must approve the spare parts used on the Scan Helicopter.

Table of Contents

1 Specifications..... 5

1.1 Electrical specifications..... 5

1.2 Mechanical specifications 6

1.3 Range of application..... 7

1.4 Scope of supply 7

1.5 Overview 8

2 Safety Regulations 9

2.1 Symbols..... 9

2.2 Safety precautions 9

2.3 Organizational measures 9

2.4 Personnel 11

2.5 Safety regarding operation of machine 11

2.6 Electrical safety 12

2.6.1 Cables..... 13

2.7 Definition of the “Safety off position” 13

2.8 Safety regarding maintenance 13

2.8.1 Lifting 14

2.8.2 Inside vehicles..... 14

3 Operation..... 15

3.1 Precautions 15

3.2 Control device 16

3.3 Start up 16

3.4 Stop 16

3.5 Safety off position 17

3.6 Troweling blades 17

4 Maintenance 18

4.1 Precautions 18

4.2 Battery Belts 18

4.3 Directions for Battery charger TC PHASE 5 18

4.4 Maintenance and inspection list 19

4.5 Cleaning the machine 19

4.6 Trouble shooting 19

4.6.1 Common faults 19

5 Spare parts..... 20

6 Warranty 23

7 EU Declaration..... 24

8 Alphabetical reference 25

9 Contact information 26

”HELICOPTER” POWER TROWEL, BATTERY OPERATED..... 27

Article number: 210000 27

Delivery supervisor (sign.) 27

”HELICOPTER” POWER TROWEL, 230VOLT DRIVEN 28

Delivery supervisor (sign.) 28

1 Specifications

The Scan Helicopter is available in to power inlets, operated with battery pack or operated with 230Volt cable. This is described later on in this chapter.

1.1 Electrical specifications

To find the specifications that apply to your machine, check the information plate on the machine.



Never connect the Scan Helicopter to any other voltage than described in this specification.



The power source must be fused according to “External fuse” in this specification; also the cables used must be marked and rated in accordance with the fuse used. Failure to comply with the correct fuses may cause fire or injuries.

Power choice	230 V 1~ both machines	110 V 1~ only battery model
Current	10 A	10 A
Voltage	200 – 240 V 1~	100 – 130 V 1~
Frequency	50 Hz +/- 5%	50 Hz +/- 5%
External fuse ¹	10 A	10 A
Power inlet ²	CEE 7/7 – 250V 16A + PE	Local standard

Table 1-1 Electrical specifications

All models are CE-marked.

1.2 Mechanical specifications

Model	Scan Helicopter
Working range	500 mm
Trowel plate speed	0-170 rpm
Mass machine	14 kg

Table 1-2 Mechanical specifications

Dimensions of Scan Helicopter

Width	500 mm
Height	1000 mm
Depth	500 mm

Dimensions of shipping box

Width	1470 mm
Height	300 mm
Depth	600 mm

Ambient temperature during operation	-20°C to +40°C	-4°F to 104°F
Ambient temperature during storage	-20°C to +70°C	-4°F to 158°F

1.3 Range of application



The Scan Helicopter is exclusively designed to process horizontal surfaces. Scan Helicopter must not be used for other purposes than stated in this user guide. The manufacturer will not be liable for damage or injury resulting from incorrect usage of the Scan Helicopter. Failure to follow the directions in this user guide will void the warranty.

1.4 Scope of supply

The following parts are included with the standard Scan Helicopter machine:

- User Guide
- Control handle
- Key to remove trowel disc
- 1 trowel disc 500mm, with a choice of 10 or 20 trowel blades
- 3 battery belts with batteries (only battery model)
- 2 battery chargers (only battery model)

Machines sold outside of Europe will be either equipped with a local standard connector for the power inlet or the mating connector will be included and fitted at the main power inlet.



Read "2.6 Electrical safety" before connecting any included connectors.

1.5 Overview



Figure 1-1 Scan Helicopter 230V



Figure 1-2 Scan Helicopter battery operated

2 Safety Regulations



Read this entire chapter carefully! Failure to comply with safety regulations may result in serious injuries or damages.

2.1 Symbols

	Notation regarding safety
	Notation regarding electrical safety
	Notation regarding safety during transport
	See reference

2.2 Safety precautions



Any machine, if it is not used according the regulations, may be hazardous for operating, setting-up and service personnel. The operating authority is responsible for compliance with the safety regulations during operation and maintenance, and for the use of safety devices supplied with the machine, as well as the provision of appropriate additional safety devices!

Eye and ear protection must be worn at all times.

Never operate the machine when it's in its upright position.

Make sure there is no debris in the work area.

Check the work area; don't use the machine if there are any foreign objects stuck out from the surface. Such objects must be removed prior operation.



Read "2.3 Organizational measures" and "2.5 Safety regarding operation of machine" thoroughly before operation!

2.3 Organizational measures



The user guide is to be kept near the location where the machine is being operated and must be within reach at all times.

In addition to this user guide general and legal regulations regarding accident prevention and environmental protection must be complied with as per local regulations.

Such duties may, for example, relate to the handling of hazardous substances, or to the provision and wearing of personal protection equipment, as well as compliance with traffic regulations.

The user guide must be supplemented by other instructions, including the duty to supervise and report incidents relating to particular working practices, for example work organization, work procedures and personnel safety.

Personnel entrusted with working with the machine must read the User Guide before starting work, in particular the “2 *Safety Regulations*” chapter. To read these instructions after work is commenced is too late. This particularly applies to incidental activities such as setting up the equipment, carrying out maintenance work or training staff to work with the machine.

From time to time the working practices of the operators are to be checked by a supervisor especially to the items regarding awareness of safety and hazards.

Operators must tie back long hair, and not wear loose clothing or jewelry including rings. There is a risk of injury through items getting caught, or being drawn into moving machinery.

Eye and ear protection must be worn at all times!

Use personnel protection equipment if necessary or required by local regulations! Take notice of all safety and hazard notices on the machine!

All safety and hazard notices at or on the machine must be kept complete and legible!

If safety-critical changes occur to the machine or its working method, the machine must be shut down immediately! The cause of the fault must be established, and rectified.

Changes, add-ons or conversion to the machine, which might impair safety, must not be made, without the manufacturer’s permission!

This applies in particular to the fitting and adjustment of safety devices.

Spare parts must comply with the technical requirements specified by the manufacturer. This is always guaranteed if original spare parts are used.

Intervals for recurring checks and inspections specified in this User Guide must be complied with!

To perform maintenance work correctly it is imperative to be equipped with the proper tools for the task in question.

Repairs may only be made by Scanmaskin Sweden AB certified service technicians.

2.4 Personnel

- Work with the machine may only be undertaken by trained personnel.
- Specify clearly the responsibilities of personnel for operation, setting up, servicing and maintenance work!
- Make sure that only authorized personnel operate or work with the machine!
- Define responsibilities of the machine operator, with regard to traffic safety regulations, and inform him not to take instructions from third parties who may not be complying with the local safety requirements.
- Personnel, who are being trained to operate equipment, may only use the machine under constant supervision of an experienced person!
- An electrician in accordance with the local regulations may only undertake work on electrical equipment.

2.5 Safety regarding operation of machine



Do not allow any method of working that impairs safety!

Recognized official procedures have to be used to ensure the machine is operated in safe and best conditions.

Only operate the machine when all safety devices and related safety equipment are present and operational!

Check the machine visually for any damage and defects at least once a day.

In the event of operational malfunctions the machine must be shut down immediately and secured!

Secure the work area around the machine in public areas providing a safety distance of at least 10 m (3.3 ft) from the machine.

Faults must be immediately rectified.

Carry out the switch on, and switch off operations in accordance with this user guide.

Before switching on the machine make sure that no-one can be endangered when the machine starts up.

Never operate the machine when it’s in its upright position.

All persons in the proximity of the machine must wear ear and eye protection as well as safety shoes. In addition the machine operator must wear close-fitting protective clothing.

Only use extension cables that are sized and marked in accordance with the overall power consumption of the machine and the valid VDE guidelines.



See “2.6 Electrical safety” for further information.

Make sure there is no debris in the work area.

Check the work area for screws or other hard objects in the concrete. Don't use the machine if there are any foreign objects stuck into the surface. Such objects must be removed prior to operation of machine

2.6 Electrical safety



The power source must be equipped with fuses according to the table in “1.1 Electrical specifications”. All cables used must be marked and rated according to the fuses used. Never connect the machine to a power source that does not provide protective earth!

Work on electrical equipment may only be undertaken by a skilled electrician or by trained persons under the supervision of a skilled electrician as well as in accordance with the local electrical engineering regulations.

Use only extension cables, that are used for extending the main cable, that are sized and marked in accordance with the overall power consumption of the machine and the valid VDE guidelines.

The electrical equipment for the plant must be inspected regularly. Defects such as loose connections or scorched cables must be rectified immediately. Call a skilled electrician or out customer services.

A second person must be in attendance whilst the electrical engineer is working on the equipment.

The work area must be secured against any third party entering the work area. Follow local electrical engineering regulations while working on the machine. Never leave a machine unattended. Use only tools that are insulated against electricity.

Only start work after you are familiar with the electrical engineering regulations that apply to the local area.

Only use voltage seekers that comply with the regulations when troubleshooting. From time to time check voltage seekers to ensure that they are operationally efficient.

2.6.1 Cables



Only use cables that are marked and rated according to the specifications in “1.1 Electrical specifications”. Don't use excessive length of the cables. If a very long cable is needed we recommend that you use a cable rated for more current and connect it to a distribution central near the machine. Never lay the cable in a loop when operating the machine, this will cause the cable to heat up and may cause fire. See “Figure 2-1” for explanation.

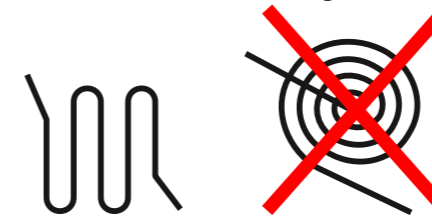

Figure 2-1 Recommended way to handle excessive cable length.

2.7 Definition of the “Safety off position”

The machine is in a safe condition where it cannot be any hazard.

How to set the machine in the Safety off position:

1. Switch off the machine
2. Wait for all drives to come to a complete stop
3. Disconnect the main power
4. Secure against unintended restart



Always disconnect the main power at the machine end to be able to prevent other persons from accidentally reconnect the main power while working on the machine.

2.8 Safety regarding maintenance

Set the machine into the Safety off position before beginning any work on the machine.



See “2.7 Definition of the “Safety off position””.

Never work on the machine while power is still connected!
All parts must have come to a complete stop before beginning any work!

Adjustment, servicing and inspection work on the period of time limits, specified in this User Guide as well as any information on the replacement or parts and equipment must be undertaken and/or complied with!

These activities may only be undertaken by qualified personnel.



The machine must not be connected to any power source while cleaning.



See “4.5 Cleaning the machine” for further information.

2.8.1 Lifting



*The machine must be secured according to local safety regulations before lifted.
No person is allowed beneath a lifted machine! Observe the machines point of balance before lifting! Failure to comply with these regulations may cause injuries or damages. Only use straps approved for the weight and circumstances!*

2.8.2 Inside vehicles



Secure the machine according to local transport safety regulations before transporting the machine inside a vehicle.

3 Operation

3.1 Precautions



Any machine, if it is not used according the regulations, may be hazardous for operating, setting-up and service personnel. The operating authority is responsible for compliance with the safety regulations during operation and maintenance, and for the use of safety devices supplied with the machine, as well as the provision of appropriate additional safety devices!

Never operate the machine without proper blades.

Eye, ear and safety shoe protection must be worn at all times.

Never operate the machine when it's in its upright position.

Make sure there is no debris in the work area.

Check the work area for screws or other hard objects in the concrete. Don't use the machine if there are any foreign objects stuck out from the surface. Before operate the machine such objects must be removed.



Read "2 Safety Regulations" before operating the machine.



The machine is equipped with a thermal protection circuit that will shut down the machine in the event of high motor temperature. Wait at least 15 minutes before operating the machine again if this occurs.

3.2 Control device

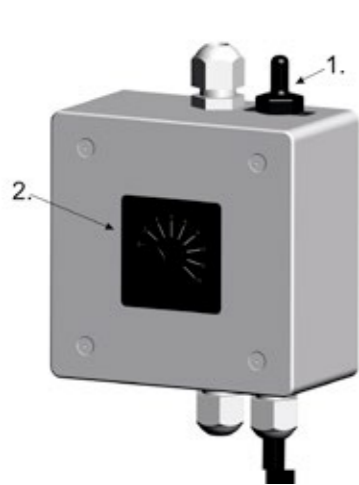

Figure 3-1 230V machine control device

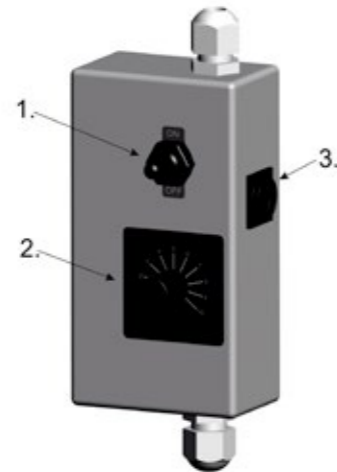



Figure 3-2 Battery machine control device

Item	Function	Description
1	Start/Stop	Start/Stops the Scan Helicopter
2	Speed	Speed of rotation 0-170rpm
3	Power input	Battery connection

Table 3-1 Description of control device

3.3 Start up

 See "3.1 Precautions" before starting the machine.

How to start the machine

- Make sure that the machine is equipped with the right blades.
- Make sure that the main power is connected to the machine.
- Grip the handle and the "dead mans grip"(4).
- Start the machine by pressing the switch (1) to "ON".
- Find the balance on the machine by lowering or raising the handle.
- Never let go of the handle during operation.

3.4 Stop

How to stop the machine

- Press the Switch (1) to "OFF"
- Wait until the machine comes to a complete stop before letting go of the handle

3.5 Safety off position

When working on the machine, either maintenance or blade change, the machine must be set to the "Safety off position". See "2.7 Definition of the "Safety off position"" for further information.

3.6 Troweling blades

There are 5 different types of troweling blades that could be chosen by, adapted to different sorts of epoxy coating. The trowel disc is removed by bracing the screw between the motor assembly and the disc, after which the disc is released manually in a clockwise direction seen from the disc's *blade side*. The disc is attached without use of any tools – it is self-locking.

4 Maintenance

4.1 Precautions

Set the machine into the Safety off position before beginning any work on the machine.

 See "2.7 Definition of the "Safety off position"".

 Read "2.6 Electrical safety" before beginning any maintenance work.

Never work on the machine while power is still connected!
All parts must have come to a complete stop before beginning any work!

Adjustment, maintenance and inspection work must be undertaken by qualified personnel.

4.2 Battery Belts

Handling of battery belts.

To retain the capacity of the batteries it is very important that the following handling instructions are observed.

After each use the batteries must always immediately be completely recharged.

This recharging is particularly necessary if the batteries will then be lying unused for around 3 weeks or longer.

Repeated storage without prior recharging will result in the batteries losing more and more charge power, with the charge power eventually dropping to 20-30% of the batteries original capacity.

4.3 Directions for Battery charger TC PHASE 5

- Connect the charger to the battery via the charging contact.
- Connect the mains cable to the wall socket.
- The red connection light comes on when charging commences.
- The green light comes on when the battery is ready for use.
- When the green and red lights are both on, the charger is continuing with adjustment/maintenance charging, and it should thus remain connected until the battery is used.
- Disconnect the mains cable from the wall socket.
- Disconnect the charger from the battery.

 The battery emits explosive gases during charging, so avoid flames and sparks.
The 24 Volt charger is only intended for lead batteries with 12 cells 14 Ah-60 Ah.
The charger must not be exposed to water.

 The machine must not be connected to any power source while cleaning.

4.4 Maintenance and inspection list

Daily	<ul style="list-style-type: none"> ▪ Inspect the trowel head ▪ Look for any other damage
12 hours after service	<ul style="list-style-type: none"> ▪ Tighten all screws

4.5 Cleaning the machine



Before starting to clean the machine, make sure it is in its "Safety off position"



The power must not be connected while cleaning the machine.

Do not use highly pressurized water to clean the machine.
Water and soap is recommended.

4.6 Trouble shooting

4.6.1 Common faults

Symptom	Cause	Correction	A ³
The machine won't start	<ul style="list-style-type: none"> ▪ There is a power failure from the power supply 	<ul style="list-style-type: none"> ▪ Inspect the fuses in the worksites fuse box ▪ Inspect cables ▪ Measure that the main voltage is present and at full voltage at the cable end near the machine. 	O E E
The machine only works for short periods	<ul style="list-style-type: none"> ▪ The motor is overheated 	<ul style="list-style-type: none"> ▪ Wait until the motor is cool again 	O
	<ul style="list-style-type: none"> ▪ The control device is damaged 	<ul style="list-style-type: none"> ▪ Replace the control device 	S
The machine is weak and might stop when on the ground.	<ul style="list-style-type: none"> ▪ There is a voltage drop at the power supply 	<ul style="list-style-type: none"> ▪ Inspect the fuses in the worksites fuse box ▪ Inspect cables ▪ Measure that the main voltage is present and at full voltage at the cable end near the machine. ▪ Make sure that the cable is not too long. If the cable should be too long, use a cable with higher rating to a distribution box nearer the machine. 	O E E O

5 Spare parts

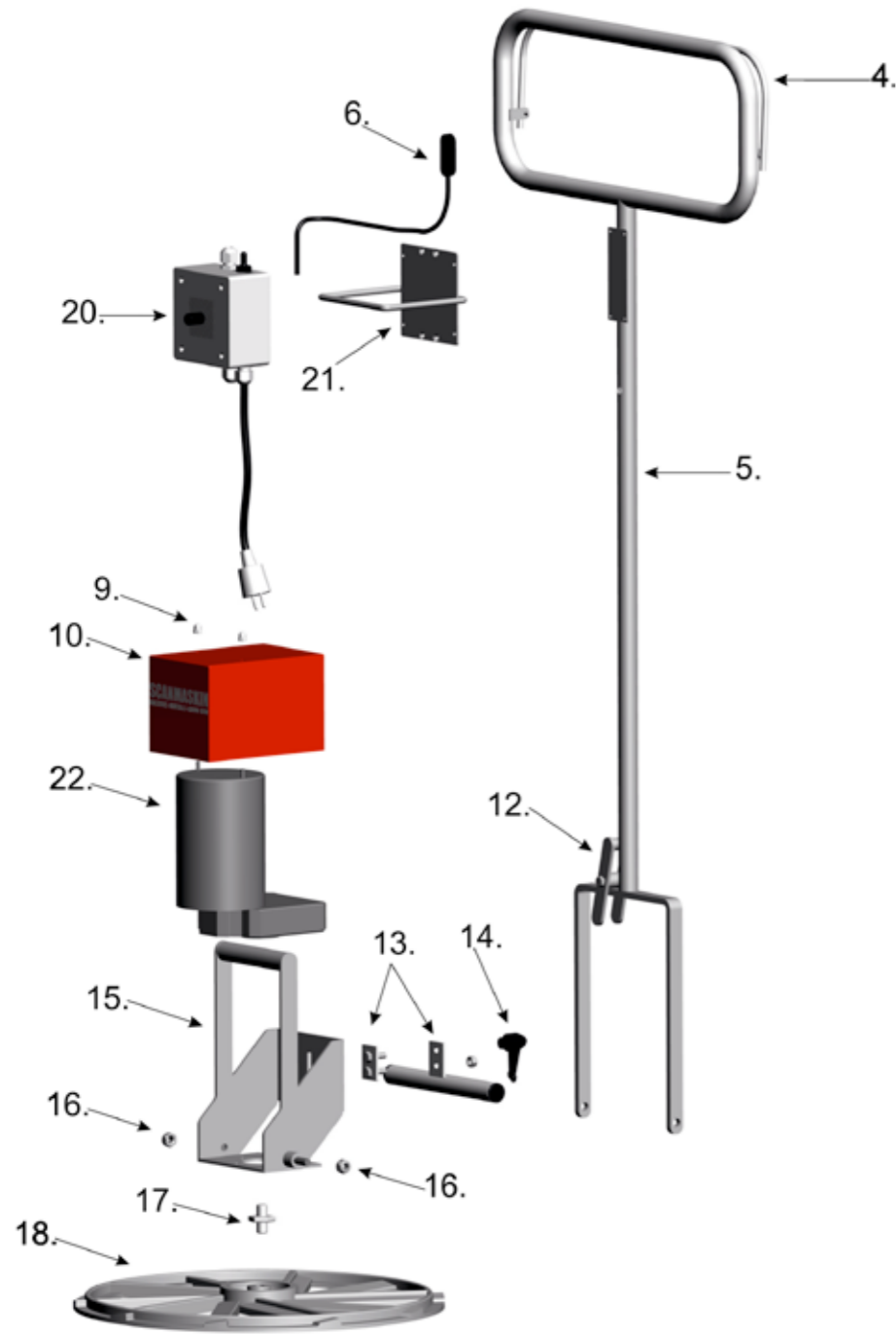

Figure 5-1 Scan Helicopter 230Volt

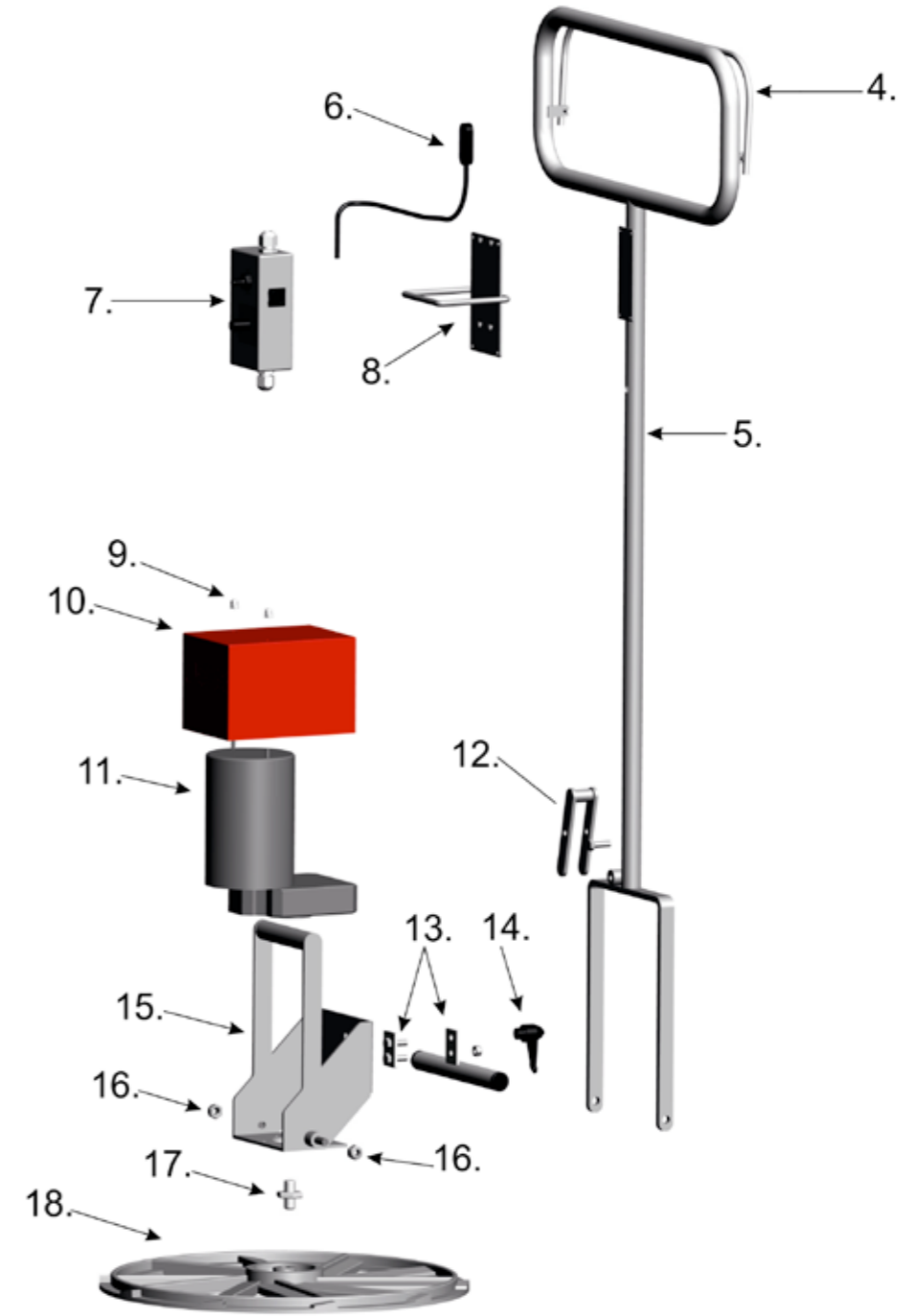

Figure 5-2 Scan Helicopter battery powered

Item	Art. no	Description
4	230021	Dead mans grip
5	230020	Handle
6	230027	Switch to dead mans grip
7	210014	Battery machine control device
8	210022	Fastening plate for battery control device
9	910019	M5 dome nut
10	230025	Motor cover
11	210018	Motor, battery machine
12	220030	Locker
13	230022	Support arm for balance
14	230024	Quick locker
15	230033	Motor frame
16	910049	M10 Nut
17	230028	Rotor bolt
18	230010	Trowel plate
20	220002	230Volt machine control device
21	220009	Fastening plate for 230Volt control device
22	220006	Motor 230V machine

Table 5-1 Parts

6 Warranty

This product from Scanmaskin Sweden AB comes with a twelve month warranty. If the product does not function satisfactorily during this period, Scanmaskin will return the product to full working order for normal use which the product is intended for – with no charge for labor or spare parts, according to the following conditions:

1. The warranty only applies to persons that have legal right to the equipment during the warranty period.
2. The manufacturer's undertaking is limited to the repair of defective parts or the replacement of these according to the manufacturer's assessment. Costs and risks for transport as well as dismantling and reinstallation of the product / products and other direct or indirect costs, associated with the repair in question, are not covered by this warranty.
3. Periodic inspections, adjustments, maintenance work and changes are not covered by the warranty.
4. Scanmaskin is not liable for any damages to grinding discs or other similar equipment.
5. The warranty only applies to material and design deficiencies and does not apply in the following cases:
 - a. Damage caused through accidents, carelessness, changes, use of spare parts or grinding tools that are not original components, or incorrect use and installation.
 - b. Damage caused by lightning, water, fire, vandalism, incorrect mains voltage, incorrect ventilation or other causes that lie outside of the manufacturer's control.
6. Scanmaskin reserves the right to modify the design – or make improvements without obligation to change previously manufactured products.
7. All warranty repairs must be carried out by Scanmaskin or by a Scanmaskin authorized repair workshop. Costs for repairs, carried out by an unauthorized workshop, will not be reimbursed by Scanmaskin. If such repairs damage this product these are not cover by the warranty agreement.

7 EU Declaration

Declaration of CE conformity

Manufacturer Scanmaskin Sweden AB
 Address Heljesvägen 10
 427 36 Lindome / Gothenburg
 Sweden

Product Grinding machine
 Product name Scan Helicopter
 Serial number _____

The product conforms with the following EU guidelines

Machine directives 2006/42/EG
 EMC 2004/108/EG
 LVD 2006/95/EG
 Harmonized standards EN ISO 13850
 EN ISO 12100-1/-2
 EN ISO 60204-1

Location of issue Lindome / Gothenburg / Sweden

Authorized representative Claes-Göran Bergstrand
 Managing Director

Scanmaskin Sweden AB
 2011-01-01



 Claes-Göran Bergstrand
 Managing Director

8 Alphabetical reference

C		O	
Contact information	26	Overview	
Control device	16	SC-450	8
E		S	
EU Declaration	24	Specifications	
F		Electrical	5
Fuse		Start	16, 22
External	5	Stop	16
I		T	
Inspection		Trouble shooting	
Maintenance and inspection list	19	common faults	19
		W	
		Warranty	23

9 Contact information

Sweden Head Office
 Heljesvägen 10
 Box 187
 SE-437 22 Lindome

Phone: +46 31 99 49 70
 Fax: +46 31 99 48 70
 E-mail: info@scanmaskin.se
 Website: www.scanmaskin.se

Denmark
 Torvegade 22
 DK-7330 Brande

Phone: +45 97 18 00 58
 Fax: +45 97 18 45 58
 E-mail: info@scanmineral.dk
 Website: www.scanmaskin.se

Norway
 Postboks 6, Furuset
 NO-1001 Oslo
 Tomtveien 12
 NO-2015 Leisund

Phone: +47 63 87 60 00
 Fax: +47 63 87 60 01
 E-mail: info@scanmaskin.no
 Website: www.scanmaskin.no

Finland
 Raudoittajantie 3 A
 FIN-06450 Porvoo / Borgå

Phone: +358 10 292 4700
 E-mail: info@scanmaskin.fi
 Website: www.scanmaskin.fi

USA
 1407 132nd Avenue Northeast, Suite 8
 Bellevue, Washington, 98005

Phone: +1 425 209 0147
 E-mail: info@scanmaskin.com
 Website: www.scanmaskin.com

”HELICOPTER” POWER TROWEL, BATTERY OPERATED

Article number: 210000

Included:	Mechanical component	Checked and inspected
Control handle		
1 trowel disc, 500mm Ø, with a choice of 10 or 20 trowelblades		
Key to the trowel disc		
3 battery belts with batteries		
2 battery chargers		

A transport / storage box in wood can be ordered separately.

The machines are always tested prior delivery.

Delivery supervisor (sign.) _____

Swedish Patent No.: 503 636
International patent application No.: PTC/SE96/00751

SCANMASKIN

MACHINES—MINERALS—KNOW-HOW

SCANMASKIN SWEDEN AB

Huvudkontor / Head office

Box 187

SE-437 22 Lindome

Phone: +46 (0)31- 99 49 70

Fax: +46 (0)31- 99 48 70

Email: info@scanmaskin.com

Besöksadress / Visiting address

Heljesvägen 10

SE-437 36 Lindome

www.scanmaskin.com