

# STONE GRINDER

**INSTRUCTION MANUAL**

5" Wet-Dry, Dry Model

5" Dust Collect Cover Model

7" Wet-Dry Model

7" Dust Collect Cover Model

ORIGINAL INSTRUCTIONS

For your personal safety,  
READ and UNDERSTAND before using.

SAVE THESE INSTRUCTIONS FOR FUTURE REFERENCE.

**MACTOOL** 

**CAUTION:**

For tools equipped with overload protection, when the motor shuts off due to overload, always run the machine with no load for at least 3 minutes to reduce temperature before returning to operation to avoid burn-out of the motor.

**CE CB** 

[www.MACTOOL.co.za](http://www.MACTOOL.co.za)

Version:20151205



Model	5" High speed model	5" Low speed model	5" Wet-Dry model
Power input	See machine nameplate		
Voltage	See machine nameplate		
No Load min <sup>-1</sup>	3000-6500	1700-3700	1700-3700
Spindle	M14		
Max. Disc Diameter	5" (125 mm)		
Soft Start & Overload Protection	With		
Dimensions	303mm ( L ) X 72mm ( W ) X 80mm ( H )		
Net Weight	2.0 kg (4.4 Lbs)		2.57 kg (5.7 Lbs)

## 5" Dry Model (High/Low Speed Model)

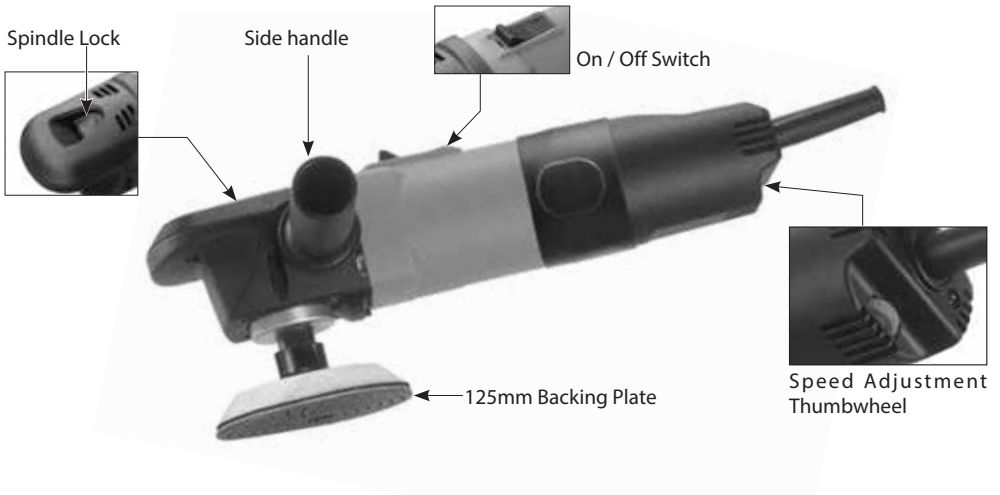

## 5" Wet-Dry Model



Model	5" Dust Collect Cover Model
Power input	See machine nameplate
Voltage	See machine nameplate
No Load min <sup>-1</sup>	1700 ~ 3700
Spindle	M14
Max. Disc Diameter	5" (125 mm)
Soft Start & Overload Protection	With
Dimensions	303mm ( L ) X 72mm ( W ) X 80mm ( H )
Net Weight	2.8 kg (6.16Lbs)

## 5" Dust Collect Cover Model

---

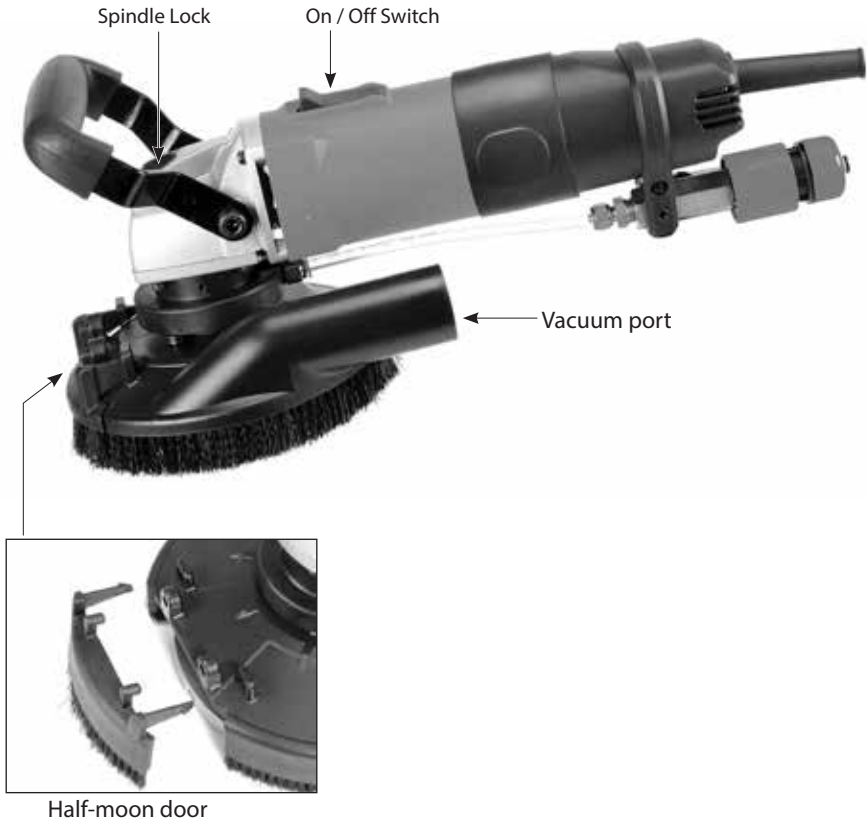

Model	7" Wet-Dry model	7" Dust Collect Cover Model
Power input	2200W	
Voltage	See machine nameplate	
No Load min <sup>-1</sup>	1000 ~ 2400	
Spindle	M14	
Max. Disc Diameter	7" (180mm)	
Soft Start & Overload Protection	With	
Dimensions	500mm ( L ) X 210mm ( W ) X 200mm ( H )	
Net Weight	5.8 kg (12.76bs)	6.00 kg (13.2Lbs)

## 7" Wet-Dry Model

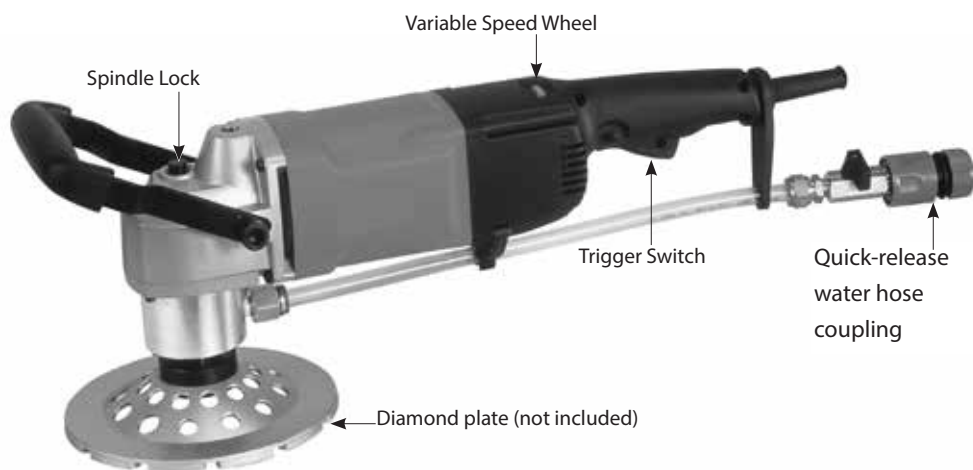

## 7" Dust Collect Cover Model

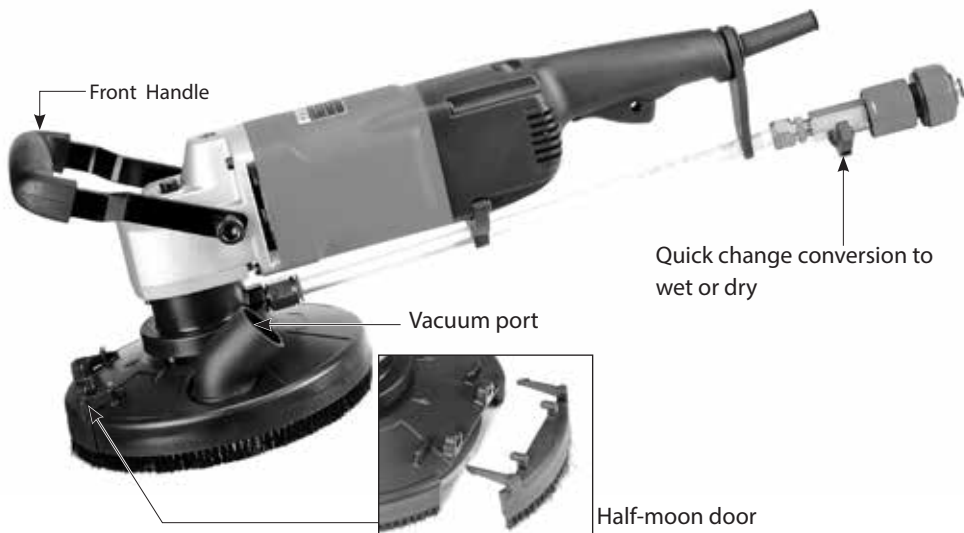

## GENERAL SAFETY INSTRUCTIONS

**WARNING! Read all safety warnings and all instructions.** Failure to follow the warnings and instructions may result in electric shock, fire and/or serious injury.

**Save all warnings and instructions for future reference.** The term “power tool” in the warnings refers to your mainsoperated (corded) power tool or battery-operated (cordless) power tool.

### 1) WORK AREA SAFETY

- a. **Keep work area clean and well lit.** Cluttered or dark areas invite accidents.
- b. **Do not operate power tools in explosive atmospheres, such as in the presence of flammable liquids, gases or dust.** Power tools create sparks which may ignite the dust or fumes.
- c. **Keep children and bystanders away while operating a power tool.** Distractions can cause you to lose control.

### 2) ELECTRICAL SAFETY

- a. **Power tool plugs must match the outlet. Never modify the plug in any way. Do not use any adapter plugs with earthed (grounded) power tools.**  
Unmodified plugs and matching outlets will reduce risk of electric shock.
- b. **Avoid body contact with earthed or grounded surfaces such as pipes, radiators, ranges and refrigerators.** There is an increased risk of electric shock if your body is earthed or grounded.
- c. **Do not expose power tools to rain or wet conditions.** Water entering a power tool will increase the risk of electric shock.
- d. **Do not abuse the cord. Never use the cord for carrying, pulling or unplugging the power tool. Keep cord away from heat, oil,**

**sharp edges or moving parts.** Damaged or entangled cords increase the risk of electric shock.

- e. **When operating a power tool outdoors, use an extension cord suitable for outdoor use.** Use of a cord suitable for outdoor use reduces the risk of electric shock.
- f. **If operating a power tool in a damp location is unavoidable, use an earth leakage circuit breaker.** Use of an earth leakage circuit breaker reduces the risk of electric shock.

### 3) PERSONAL SAFETY

- a. **a) Stay alert, watch what you are doing and use common sense when operating a power tool. Do not use a power tool while you are tired or under the influence of drugs, alcohol or medication.** A moment of inattention while operating power tools may result in serious personal injury.
- b. **b) Use personal protective equipment. Always wear eye protection.** Protective equipment such as dust mask, non-skid safety shoes, hard hat, or hearing protection used for appropriate conditions will reduce personal injuries.
- c. **Prevent unintentional starting. Ensure the switch is in the off-position before connecting to power source and/or battery pack, picking up or carrying the tool.** Carrying power tools with your finger on the switch or energising power tools that have the switch on invites accidents.
- d. **Remove any adjusting key or wrench before turning the power tool on.** A wrench or a key left attached to a rotating part of the power tool may result in personal injury.
- e. **Do not overreach. Keep proper footing and balance at all times.** This enables better control of the power tool in unexpected situations.
- f. **Dress properly. Do not wear loose clothing**

or jewelry. Keep your hair, clothing and gloves away from moving parts. Loose clothes, jewelry or long hair can be caught in moving parts.

- g. If devices are provided for the connection of dust extraction and collection facilities, ensure these are connected and properly used.** Use of dust collection can reduce dust-related hazards.

#### 4) POWER TOOL USE AND CARE

- a. Do not force the power tool. Use the correct power tool for your application.** The correct power tool will do the job better and safer at the rate for which it was designed.
- b. Do not use the power tool if the switch does not turn it on and off.** Any power tool that cannot be controlled with the switch is dangerous and must be repaired.
- c. Disconnect the plug from the power source and/or the battery pack from the power tool before making any adjustments, changing accessories, or storing power tools.** Such preventive safety measures reduce the risk of starting the power tool accidentally.
- d. Store idle power tools out of the reach of children and do not allow persons unfamiliar with the power tool or these instructions to operate the power tool.** Power tools are dangerous in the hands of untrained users.
- e. Maintain power tools. Check for misalignment or binding of moving parts, breakage of parts and any other condition that may affect the power tool's operation. If damaged, have the power tool repaired before use.** Many accidents are caused by poorly maintained power tools.
- f. Keep cutting tools sharp and clean.** Properly maintained cutting tools with sharp cutting edges are less likely to bind and are easier to control.
- g. Use the power tool, accessories and tool**

bits etc., in accordance with these instructions, taking into account the working conditions and the work to be performed. Use of the power tool for operations different from those intended could result in a hazardous situation.

#### 5) SERVICE

Have your power tool serviced by a qualified repair person using only identical replacement parts. This will ensure that the safety of the power tool is maintained.

#### Symbols used in this manual

- V.....volts
- A.....amperes
- Hz.....hertz
- W.....watt
- ~.....alternating current
- $n_0$ .....no load speed
- min<sup>-1</sup>.....revolutions or reciprocation
- per minute

 .....warning of general danger

 .....class II tool

 .....with electrical earth

 .....read these instructions

 .....always wear eye protection

 .....always wear a dust mask.

 .....always wear hearing protection

 .....wear safety-approved hard hat

 do not dispose of electric tools, accessories and packaging together with household waste material

## **SAFETY WARNINGS COMMON FOR GRINDING, SANDING, POLISHING OR ABRASIVE CUTTING - OFF OPERATIONS:**

- a. **This power tool is intended to function as a grinder, sander, polisher or cut-off tool. Read all safety warnings, instructions, illustrations and specifications provided with this power tool.** Failure to follow all instructions listed below may result in electric shock, fire and/or serious injury.
- b. **Operations such as wire brushing are not recommended to be performed with this power tool.** Operations for which the power tool was not designed may create a hazard and cause personal injury.
- c. **Do not use accessories which are not specifically designed and recommended by the tool manufacturer.** Just because the accessory can be attached to your power tool, it does not assure safe operation.
- d. **The rated speed of the accessory must be at least equal to the maximum speed marked on the power tool.** Accessories running faster than their rated speed can break and fly apart.
- e. **The outside diameter and the thickness of your accessory must be within the capacity rating of your power tool.** Incorrectly sized accessories cannot be adequately guarded or controlled.
- f. **The arbour size of wheels, flanges, backing pads or any other accessory must properly fit the spindle of the power tool.** Accessories with arbour holes that do not match the mounting hardware of the power tool will run out of balance, vibrate excessively and may cause loss of control.
- g. **Do not use a damaged accessory. Before each use inspect the accessory such as abrasive wheels for chips and cracks, backing pad for cracks, tear or excess wear, wire brush for loose or cracked wires. If power tool or accessory is dropped, inspect for damage or install an undamaged accessory. After inspecting and installing an accessory, position yourself and bystanders away from the plane of the rotating accessory and run the power tool at maximum no-load speed for one minute.** Damaged accessories will normally break apart during this test time.
- h. **Wear personal protective equipment. Depending on application, use face shield, safety goggles or safety glasses. As appropriate, wear dust mask, hearing protectors, gloves and workshop apron capable of stopping small abrasive or workpiece fragments. The eye protection must be capable of stopping flying debris generated by various operations .** The dust mask or respirator must be capable of filtrating particles generated by your operation. Prolonged exposure to high intensity noise may cause hearing loss.
- i. **Keep bystanders a safe distance away from work area. Anyone entering the work area must wear personal protective equipment.** Fragments of workpiece or of a broken accessory may fly away and cause injury beyond immediate area of operation.
- j. **Hold the power tool by insulated gripping surfaces only, when performing an operation where the cutting accessory may contact hidden wiring or its own cord.** Cutting accessory contacting a "live" wire may make exposed metal parts of the power tool "live" and could give the operator an electric shock.
- k. **Position the cord clear of the spinning accessory.** If you lose control, the cord may be cut or snagged and your hand or arm may be pulled into the spinning accessory.
- l. **Never lay the power tool down until the accessory has come to a complete stop.** The spinning accessory may grab the surface and pull the power tool out of your control.
- m. **Do not run the power tool while carrying it**

- at your side.** Accidental contact with the spinning accessory could snag your clothing, pulling the accessory into your body.
- n. Regularly clean the power tool's air vents.** The motor's fan will draw the dust inside the housing and excessive accumulation of powdered metal may cause electrical hazards.
- o. Do not operate the power tool near flammable materials.** Sparks could ignite these materials.

## KICKBACK AND RELATED WARNINGS

Kickback is a sudden reaction to a pinched or snagged rotating wheel, backing pad, brush or any other accessory. Pinching or snagging causes rapid stalling of the rotating accessory which in turn causes the uncontrolled power tool to be forced in the direction opposite of the accessory's rotation at the point of the binding. For example, if an abrasive wheel is snagged or pinched by the workpiece, the edge of the wheel that is entering into the pinch point can dig into the surface of the material causing the wheel to climb out or kick out. The wheel may either jump toward or away from the operator, depending on direction of the wheel's movement at the point of pinching. Abrasive wheels may also break under these conditions.

Kickback is the result of power tool misuse and/or incorrect operating procedures or conditions and can be avoided by taking proper precautions as given below.

- a. Maintain a firm grip on the power tool and position your body and arm to allow you to resist kickback forces. Always use auxiliary handle, if provided, for maximum control over kickback or torque reaction during start-up.** The operator can control torque reactions or kickback forces, if proper precautions are taken.
- b. Never place your hand near the rotating accessory.** Accessory may kickback over your hand.
- c. Do not position your body in the area where power tool will move if kickback occurs.** Kickback will propel the tool in direction opposite to the wheel's movement at the point of snagging.
- d. Use special care when working corners, sharp edges etc. Avoid bouncing and snagging the accessory.** Corners, sharp edges or bouncing have a tendency to snag the rotating accessory and cause loss of control or kickback.
- e. Do not attach a saw chain woodcarving blade or toothed saw blade.** Such blades create frequent kickback and loss of control.

## SAFETY WARNINGS SPECIFIC FOR GRINDING AND ABRASIVE CUTTING-OFF OPERATIONS

- a. Use only wheel types that are recommended for your power tool and the specific guard designed for the selected wheel.** Wheels for which the power tool was not designed cannot be adequately guarded and are unsafe.
- b. The guard must be securely attached to the power tool and positioned for maximum safety, so the least amount of wheel is exposed towards the operator.** The guard helps to protect the operator from broken wheel fragments, accidental contact with wheel and sparks that could ignite clothing.
- c. Wheels must be used only for recommended applications. For example: do not grind with the side of cut-off wheel.** Abrasive cut-off wheels are intended for peripheral grinding, side forces applied to these wheels may cause them to shatter.
- d. Always use undamaged wheel flanges that are of correct size and shape for your**



**selected wheel.** Proper wheel flanges support the wheel thus reducing the possibility of wheel breakage. Flanges for cut-off wheels may be different from grinding wheel flanges.

- e. **Do not use worn down wheels from larger power tools.** Wheel intended for larger power tool is not suitable for the higher speed of a smaller tool and may burst.

## **ADDITIONAL SAFETY WARNINGS SPECIFIC FOR ABRASIVE CUTTING-OFF OPERATIONS**

- a. **Do not “jam” the cut-off wheel or apply excessive pressure. Do not attempt to make an excessive depth of cut.** Overstressing the wheel increases the loading and susceptibility to twisting or binding of the wheel in the cut and the possibility of kickback or wheel breakage.
- b. **Do not position your body in line with and behind the rotating wheel.** When the wheel, at the point of operation, is moving away from your body, the possible kickback may propel the spinning wheel and the power tool directly at you.
- c. **When wheel is binding or when interrupting a cut for any reason, switch off the power tool and hold the power tool motionless until the wheel comes to a complete stop. Never attempt to remove the cut-off wheel from the cut while the wheel is in motion otherwise kickback may occur.** Investigate and take corrective action to eliminate the cause of wheel binding.
- d. **Do not restart the cutting operation in the workpiece. Let the wheel reach full speed and carefully re-enter the cut.** The wheel may bind, walk up or kickback if the power tool is restarted in the workpiece..
- e. **Support panels or any oversized workpiece to minimize the risk of wheel pinching and kickback.** Large workpieces

tend to sag under their own weight. Supports must be placed under the workpiece near the line of cut and near the edge of the workpiece on both sides of the wheel.

- f. **Use extra caution when making a “pocket cut” into existing walls or other blind areas.** The protruding wheel may cut gas or water pipes, electrical wiring or objects that can cause kickback.

## **SAFETY WARNINGS SPECIFIC FOR SANDING OPERATIONS**

**Do not use excessively oversized sanding disc paper. Follow manufacturers recommendations, when selecting sanding paper.** Larger sanding paper extending beyond the sanding pad presents a laceration hazard and may cause snagging, tearing of the disc or kickback.

## **SAFETY WARNINGS SPECIFIC FOR POLISHING OPERATIONS**

**Do not allow any loose portion of the polishing bonnet or its attachment strings to spin freely. Tuck away or trim any loose attachment strings.** Loose and spinning attachment strings can entangle your fingers or snag on the workpiece.

## **SPECIFIC SAFETY RULES**

1. **Keep hands away from rotating disc area at all times!**
2. **Prolonged breathing of airborne dust from grinding operations may effect respiratory function:**  
Always use a vacuum cleaner with a bag approved for fine dust installed.  
Always wear a respirator approved for dust

and mist.

3. **Grinding LEAD-BASED paint is extremely toxic and should not be attempted.** Only allow professionals with special training and equipment perform this task.
4. **Maintain proper footing and balance at all times.** Do not overreach.
5. **Always wear appropriate safety equipment when operating.**
6. **Important: After completing operation,** switch off the switch and wait for the coasting disc to stop completely before putting the tool down.
7. **Never operate** the tool in an area with flammable solids, liquids, or gases. Sparks from the commutator/carbon brushes could cause a fire or explosion.
8. **There are certain applications for which this tool was designed.** The manufacturer strongly recommends that this tool NOT be modified and/or used for any application other than for which it was designed. If you have any questions relative to its application DO NOT use the tool until you have written the manufacturer and have been advised.
9. **Use the machine with both hands at all times.** Loss of control can cause personal injury.
10. **Keep power supply cord clear from the working range of the machine.** Always lead the cable away behind you.
11. **Immediately switch off the machine if unusual vibrations or if other malfunctions occur.** Check the machine in order to find out the cause.
12. **The dust that arises when working with this tool can be harmful to health.** Use a dust absorption system and wear a suitable dust protection mask and remove deposited dust with a vacuum cleaner.

## FUNCTIONAL DESCRIPTION

This Stone Grinder is designed for finish grinding

of stone. Various grits of hook & loop backed diamond polishing pads are available for this purpose.

## ELECTRICAL CONNECTION

The network voltage must conform to the voltage indicated on the tool name plate. Under no circumstances should the tool be used when the power supply cable is damaged.

A damaged cable must be replaced immediately by a qualified Customer Service Center. Do not try to repair the damaged cable yourself. The use of damaged power cables can lead to an electric shock.

## EXTENSION CABLE

If an extension cable is required, it must have a sufficient cross-section so as to prevent an excessive drop in voltage or overheating. An excessive drop in voltage reduces the output and can lead to failure of the motor. The following table shows you the correct cable diameter as a function of the cable length for this machine. Use only approved extension cables. Never use two extension cables together. Instead, use one long one.

Total Extension Cord Length (feet)	Cord Size (AWG)
25	16
50	12
100	10
150	8
200	6

## UNPACKING

Carefully remove the tool and all loose items from the shipping container.

Retain all packing materials until after you have inspected and satisfactorily operated the machine.

## CARTON CONTENTS

1. Stone Grinder machine
2. Instruction manual
3. Side handle
4. 125mm backing plate

**DO NOT OPERATE THIS TOOL UNTIL YOU READ AND UNDERSTAND THE ENTIRE INSTRUCTION MANUAL**

## INSTALLING BACKING PLATE AND DIAMOND POLISHING PADS

1. Unplug the machine.
2. Thread on the Backing Plate onto the arbor. Press the Spindle Lock and rotate the arbor until it engages. Tighten backing plate.
3. Select the desired grit of diamond polishing pad (not included) and adhere to the Backing Plate by pressing together the hook & loop backings.
4. Removal is the opposite of assembly.

## INSTALLING OTHER ASSESSORIES

1. Unplug the machine.
2. Install the Inner Flange with the shoulder facing up.
3. Then install the Assesory and thread on the Outer Flange.
4. Press the Spindle Lock and rotate the arbor until it engages. Tighten using the supplied Lock Nut Wrench.
5. Removal is the opposite of assembly.

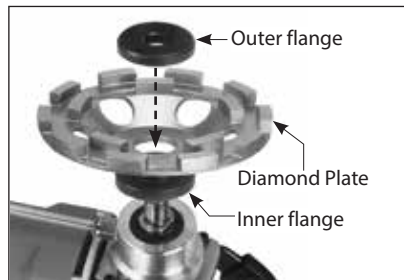
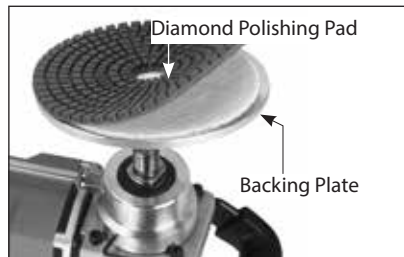

## 5" Dust Collector Cover Model Hoop and loop plate for Diamond polishing

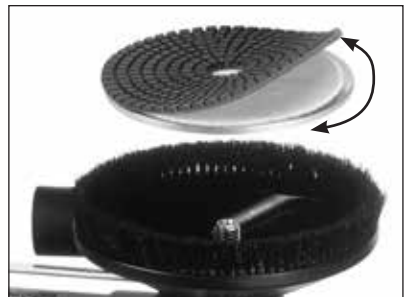

## DIAMOND PLATE WITH FLANGES

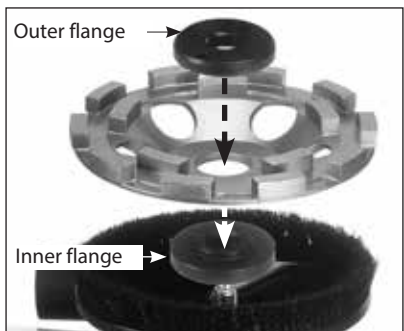

## 7" Dust Collector Cover Model Diamond plate with thread

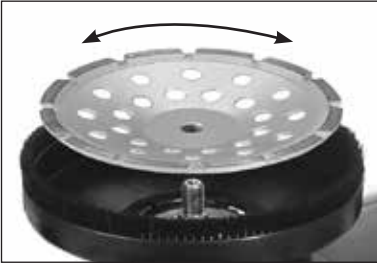

## Diamond plate with flanges

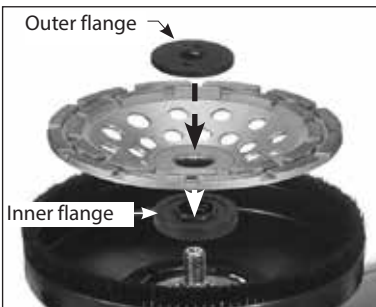

## SPECIAL INSTRUCTIONS FOR WATER FEED EQUIPPED MACHINES

Water feed models provide water directly to the workpiece.

**WARNING: Never allow water to enter the motor or its power supply cord! Electrocutation could result!**

**WARNING: This machine is equipped with a Portable Residual Current Device (PRCD) also known as a Ground Fault Circuit Interrupter (GFCI). Always use this device whenever using the machine to reduce the risk of shock hazards. Always position the device PRCD as close as possible to the power source.**

**Test the PRCD device before each use. Press the "Test" button to test. Press the "Reset"**

**button to energize the circuit to the machine.**

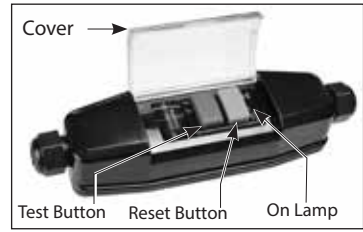

**WARNING: Never use the machine without the PRCD fault-current safety switch supplied.**

**WARNING: Check all connections of the water feed system to ensure there are no leaks. Inspect hoses and other critical parts which could deteriorate.**

**WARNING: If you detect a leak in any part of the water supply system, shut the machine down immediately and repair the fault.**

**WARNING: The maximum water pressure should not exceed 70 psi (4 bar).**

To install, attach the quick-release Water Coupling to your water supply hose. Connect the coupling to the Water Nipple. Regulate the water flow to the desired amount by adjusting the tap at the water supply.

The Water Feed Collar can be turned to the desired position by first loosening the 3 set screws using the supplied L-hex key.

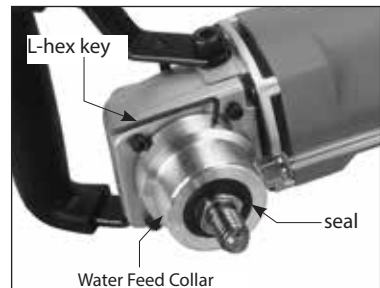

The seals in the Water Feed Collar are a wearing part. When they are worn, water will be seen to

leak out of the top or bottom of the collar. At this point, the seals must be replaced. To replace, loosen the 3 set screws to remove the Water Feed Collar, drive out the old seals and press in new ones.

## STARTING AND STOPPING TOOL

Make sure that the power circuit voltage is the same as that shown on the specification plate of the machine and that switch is "OFF" before connecting the tool to the power circuit.

### Switching The Machine On And Off

(5" Dry Model (High/Low Speed Model)

(5" Wet-Dry Model)

(5" Dust Collector Cover Model)

#### To switch on:

While holding with the left hand on the side handle and the right hand on the main handle, push forward and down on the Switch Slider until it clicks to the "on" position. Anticipate and be ready for the start up torque when the machine first starts.

**WARNING: This is a lock-on switch, so whenever it is on, it will remain locked on until you actively turn it off. Before plugging the tool in, always ensure that the switch is in the "Off" position. Whenever there is a power outage, always remember to switch the tool off. Otherwise, when the power comes back on, the machine would start unexpectedly-causing a hazardous situation.**

#### To switch off:

Press down on the back of the Switch Slider to release the switch. After the machine has been switched off, the disc will still rotate for a time. Take care that parts of your body do not come into contact with the disc and do not set the machine

down while it is still rotating!

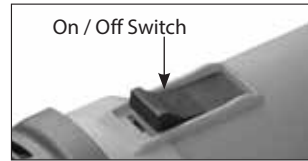

### Switching the machine on and off

(7" Wet-Dry Model)

(7" Dust Collector Cover Model)

#### To switch on:

While holding with the left hand on the front grip and the right hand on the main handle, squeeze the trigger switch to the "on" position. Anticipate and be ready for the start up torque when the machine first starts.

This is a lock-on type switch, so for continued operation, the locking pin may be pressed. To shut off, first re-squeeze and then release the trigger switch to release the lock.

#### To switch off:

Release the trigger switch. If the switch has been locked on, first re-squeeze and then release the trigger switch to release the lock. After the machine has been switched off, the grinding wheel will still rotate for a time. Take care that parts of your body do not come into contact with the wheel and do not set the machine down while it is still rotating!

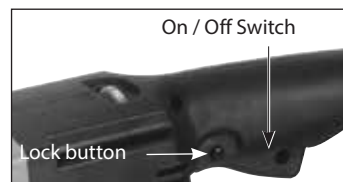

## ELECTRONIC SPEED CONTROL SYSTEMS

These machines are equipped with tachometer feedback speed stabilization which rigidly maintains the selected speed.

**CAUTION: Care must be taken not to overload the motor, as the motor will not slow under load like a conventional motor. So if the machine is forced so hard that it slows down, it will be dangerously overloaded and can easily overheat.**

### ADJUSTING THE ROTATION SPEED

(5" Dry Model (High/Low Speed Mode )

(5" Wet-Dry Model)

(5" Dust Collect Cover Model)

The speed of the machine is variable to suit different tasks. It can be adjusted from 3,000/min up to 6,500/min for high speed models, or 1,700/min up to 3,700/min for low speed models by using the thumb wheel. Turn in the rightward direction to increase the speed and in the leftward direction to decrease the speed.



### ADJUSTING THE ROTATION SPEED

(7" Wet-Dry Model)

(7" Dust Collect Cover Model)

The speed of the machine is variable to suit different tasks. It can be adjusted from 1000/min up to 2400/min by using the thumb wheel. Turn in the rightward direction to increase the speed and

in the leftward direction to decrease the speed.

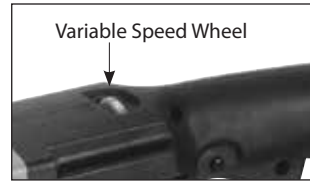

### THE HALF-MOON DOOR

The sanding plate cover is equipped with a removable half-moon door. This is to allow the operator to sand right up to the edge or into a corner.

Dust collection will not be ideal while the half-moon door is removed, so the door should only be removed when necessary and then replaced immediately.

To remove, first shut down the machine and unplug the power supply cable.

Then press the 2 tangs which retain the half-moon door just enough to release it and lift the door away. Put the door in a safe place where it will not be lost or damaged when it is time to replace it.

To replace, line up the locating pins in the sanding plate cover and snap the tangs in place.



### HOW TO USE THE TOOL

Effective control of this machine requires **two-handed** operation for maximum safety and control.

The proper hold is to keep one hand on the main handle and the other hand on the grip. It is vitally

important to keep stable footing at all times,

## GRINDING OPERATIONS

Once the machine is set up and all safety measures and equipment are in place, begin by turning on the machine.

Begin working and contact the workpiece. It is not necessary to use excessive down force. Allow the machine to work at the pace it was intended.

## MAINTENANCE

### KEEP TOOL CLEAN

Every 50 hours of operation blow compressed air through the motor while running at no load to clean out accumulated dust. (If operating in especially dusty conditions, perform this operation more often.)

Periodically blow out all air passages with dry compressed air. All plastic parts should be cleaned with a soft damp cloth. NEVER use solvents to clean plastic parts. They could possibly dissolve or otherwise damage the material.

Wear safety glasses while using compressed air.

### THE CARBON BRUSHES

The carbon brushes are a normal wearing part and must be replaced when they reach their wear limit.

**NOTE: Checking and replacing the carbon brushes should be entrusted to a qualified service center.**

The carbon brushes furnished will last approximately 50 hours of running time or 10,000 on/off cycles. Replace both carbon brushes when either has less than 1/4" length of carbon

remaining.

### 5" Dry Model (High/Low Speed Model ) 5" Wet-Dry Model 5" Dust Collect Cover Model

To inspect or replace brushes, first unplug the machine and lay it on its side. Remove the 2 screws to remove the Tail Cover. Slide off the Tail Cover.

Using needle-nose pliers, rotate the spiral spring to relieve the tension on the brush and slide it out of the holder.

Uplug the female spade connector which holds the brush lead and remove the Carbon Brush.

Ensure the slot for the Variable Speed Wheel is lined up and slide the Tail Cover into place. Then tighten the 2 screws.

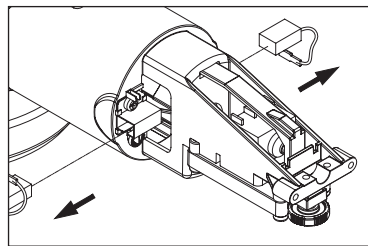
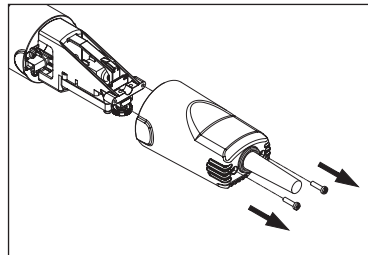

### 7" Wet-Dry Model 7" Dust Collect Cover Model

To inspect or replace brushes, first unplug the machine. Carefully remove the 4 screws to separate the rear handle halves and then remove the 4 screws which connect the handle to the motor housing. Lift away the left-hand handle half first. There will still be wires connected to the rear handle, so take care that these are not stressed.

Simply hold the rear handle off to one side. Next remove the two screws holding on the Electronics Unit to allow access to the Brush screws. Hold the Electronics Unit off to one side and avoid stressing the wires. Rotate the spiral spring to relieve the tension on the brush and slide it out of the holder. Unscrew the two screws which hold the brush leads and remove the Carbon Brushes.

**NOTE: When putting the Carbon Brushes back into the Carbon Brush Holders it is essential that both flanges go back inside the holder.**

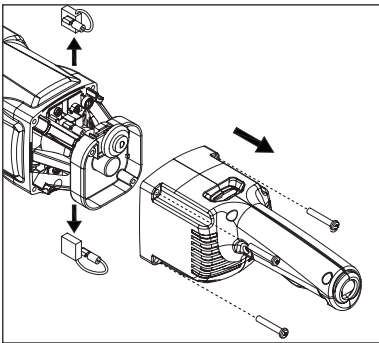

**NOTE: To reinstall the same brushes, first make sure the brushes go back in the way they came out. Otherwise a break-in period will occur that will reduce motor performance and increase brush wear.**

Replacing is the reverse of removal. When Replacing all covers, take great care that all wires are in place and not in a position to be pinched when they are retightened. It is recommended that, at least once a year, you take the tool to an Authorized Service Center for a thorough cleaning and lubrication.

**If the replacement of the power supply cord is necessary, this has to be done by the manufacturer or their agent in order to avoid a safety hazard.**

**WARNING: All repairs must be entrusted to an authorized service center.** Incorrectly performed repairs could lead to injury or death.



# 5" Stone Grinders Wiring

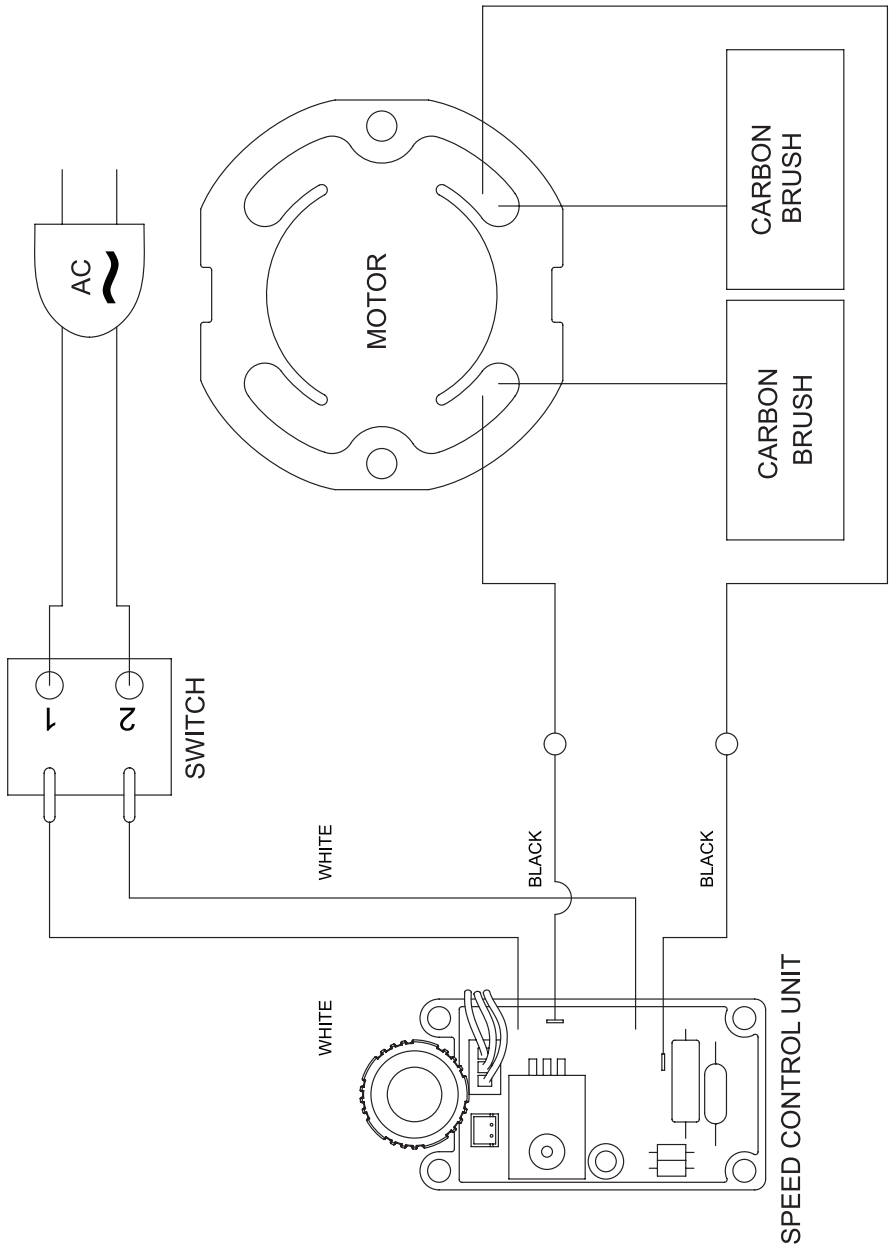

# 7" Stone Grinders Wiring

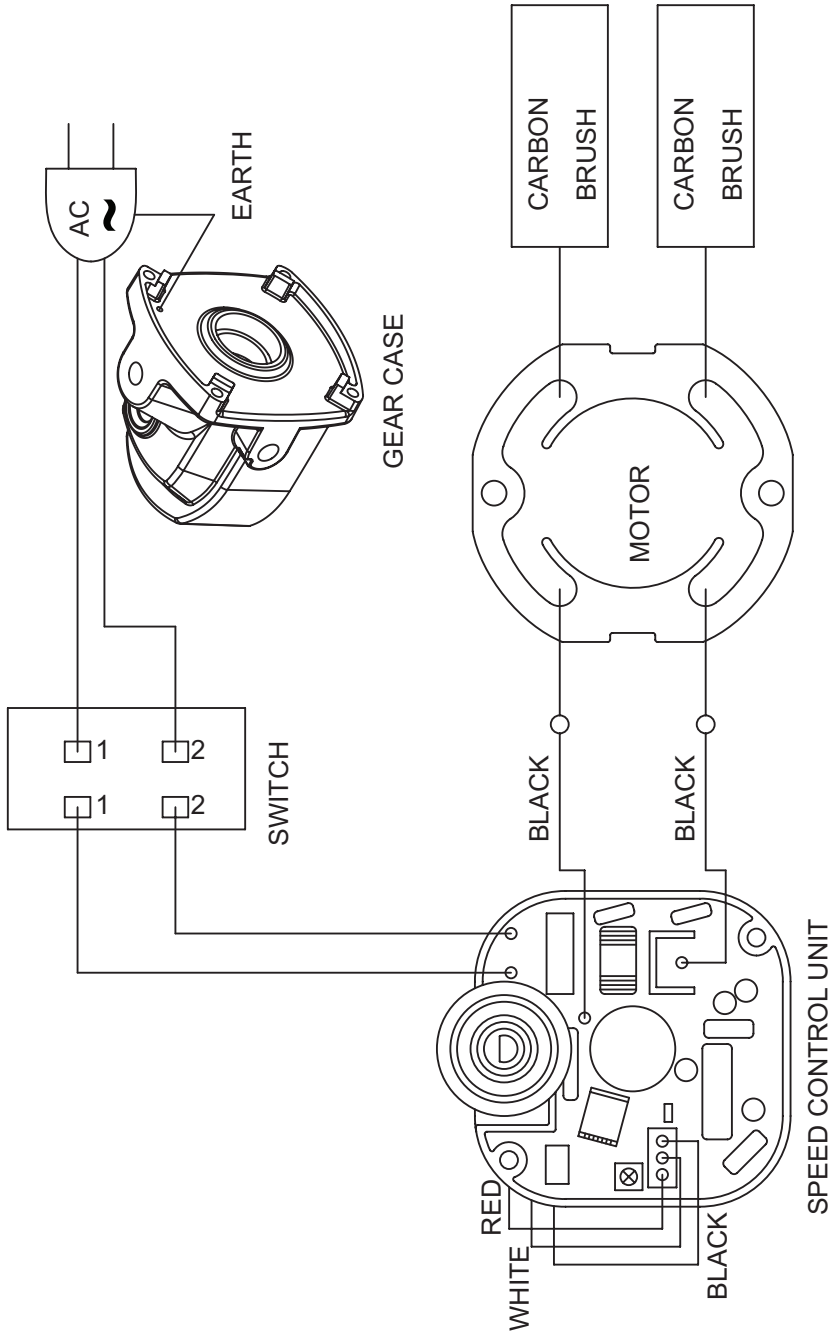

# 5" Stone Grinders Exploded View(1200W)

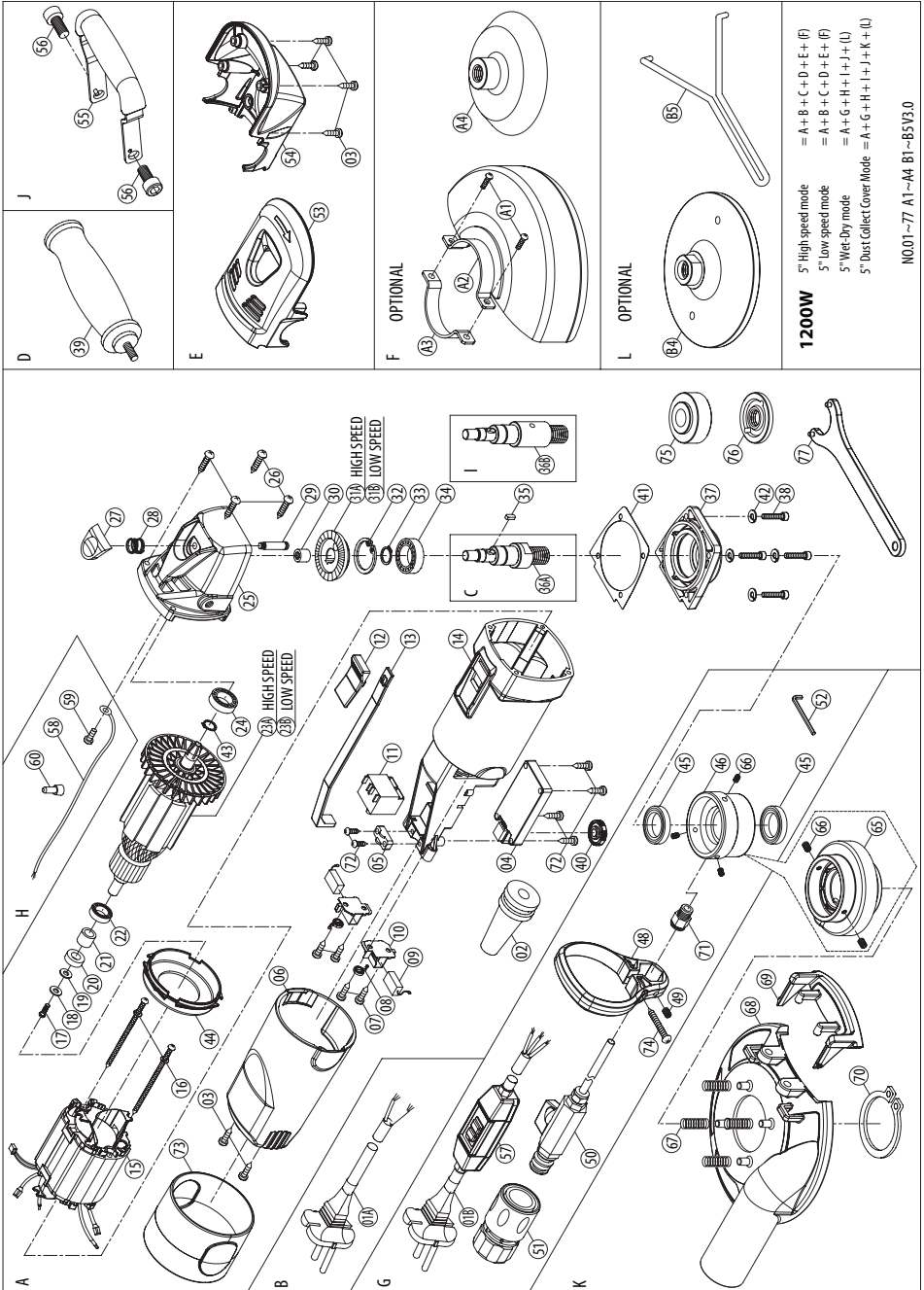

## 5" High speed model Stone Grinders Parts List (1200W)

NO.	Parts Name	Q'TY	NO.	Parts Name	Q'TY
1A	POWER SUPPLY CABLE	1	30	NEEDLE BEARING HK 0810	1
1B	N/A	-	31A	BEVEL GEAR-HIGH SPEED M1.2 x 33T (HIGH SPEED)	1
2	CORD ARMOR	1	32.)	INTERNAL CIRCLIP R-35	1
3	SCREW M4 x 16	6	33	EXTERNAL CIRCLIP S-15	1
4	ELECTRONICS BOARD	1	34	BEARING 6202-2RS	1
4	ELECTRONICS BOARD	1	35	PARALLEL KEY 3 x 3 x 8	1
5	CABLE CLIP	1	36A	SPINDLE M14	1
6	TAIL COVER	1	37	GEAR PLATE	1
7	SCREW M4 x 10	4	38	SCREW M4 x 16	4
8	SPIRAL TORSION SPRING	2	39	SIDE HANDLE	1
9	CARBON BRUSH 7 x 11 + 33L + FLDNBI-110	2	40	THUMB WHEEL	1
10	CARBON BRUSH HOLDER	2	41	GASKET	1
11	SWITCH	1	42	SPRING WASHER M4	4
12	SWITCH SLIDER	1	43	EXTERNAL CIRCLIP S-12	1
13	SWITCH LEVER	1	44	FAN SHROUD	1
14	MOTOR HOUSING	1	45~52	N/A	-
15	STATOR	1	53	GEARBOX COVER - UPPER	1
16	STATOR SCREW M4 x 60	2	54	GEARBOX COVER - LOWER	1
17	SCREW M4 x 10	1	55~71	N/A	-
18	FLAT WASHER $\phi 4 \times \phi 10 \times 1$	1	72	SCREW M4 x 14	6
19	PLASTIC WASHER $\phi 4 \times \phi 11 \times 1$	1	73	RUBBER SLEEVE	1
20	PICKUP MAGNET $\phi 8 \times \phi 15 \times 5$	1	74	N/A	-
21	SPACER $\phi 8 \times \phi 12 \times 10.5$	1	75	INNER FLANGE	1
22	BEARING 608-2RU	1	76	OUTER FLANGE	1
23A	ARMATURE-HIGH SPEED M1.2 x 8T (HIGH SPEED)	1	77	LOCK NUT WRENCH	1
24	BEARING 6001-LLU	1	<b>(Optional for model High speed model&amp;Low speed model)</b>		
25	GEAR CASE	1	A1	SCREW M4 x 10	2
26	SCREW M4 x 25	4	A2	GUARD	1
27	SPINDLE LOCK BUTTON	1	A3	GUARD BRACKET	1
28	COIL SPRING $\phi 0.9 \times \phi 10 \times \phi 11.8 \times 13.5L \times 4T$	1	A4	4" SANDING PAD 4"	1
29	SPINDLE LOCK	1			

## 5" Low speed model Stone Grinders Parts List (1200W)

NO.	Parts Name	Q'TY	NO.	Parts Name	Q'TY
1A	POWER SUPPLY CABLE	1	30	NEEDLE BEARING HK 0810	1
1B	N/A	-	31B	BEVEL GEAR-LOW SPEED M1.15 x 43T (LOW SPEED)	1
2	CORD ARMOR	1	32	INTERNAL CIRCLIP R-35	1
3	SCREW M4 x 16	6	33	EXTERNAL CIRCLIP S-15	1
4	ELECTRONICS BOARD	1	34	BEARING 6202-2RS	1
5	CABLE CLIP	1	35	PARALLEL KEY 3 x 3 x 8	1
6	TAIL COVER	1	36A	SPINDLE M14	1
7	SCREW M4 x 10	4	37	GEAR PLATE	1
8	SPIRAL TORSION SPRING	2	38	SCREW M4 x 16	4
9	CARBON BRUSH 7 x 11 + 33L + FLDNBI-110	2	39	SIDE HANDLE	1
10	CARBON BRUSH HOLDER	2	40	THUMB WHEEL	1
11	SWITCH	1	41	GASKET	1
12	SWITCH SLIDER	1	42	SPRING WASHER M4	4
13	SWITCH LEVER	1	43	EXTERNAL CIRCLIP S-12	1
14	MOTOR HOUSING	1	44	FAN BAFFLE	1
15	STATOR	1	45~52	N/A	-
16	STATOR SCREW M4 x 60	2	53	GEARBOX COVER - UPPER	1
17	SCREW M4 x 10	1	54	GEARBOX COVER - LOWER	1
18	FLAT WASHER $\phi 4 \times \phi 10 \times 1$	1	55~71	N/A	-
19	PLASTIC WASHER $\phi 4 \times \phi 11 \times 1$	1	72	SCREW M4 x 14	6
20	PICKUP MAGNET $\phi 8 \times \phi 15 \times 5$	1	73	RUBBER SLEEVE	1
21	SPACER $\phi 8 \times \phi 12 \times 10.5$	1	74	N/A	1
22	BEARING 608-2RU	1	75	INNER FLANGE	1
23B	ARMATURE-LOW SPEED M1.15 x 6T (LOW SPEED)	1	76	OUTER FLANGE	1
24	BEARING 6001-LLU	1	77	LOCK NUT WRENCH	1
25	GEAR CASE	1	<b>(Optional for model High speed model&amp;Low speed model)</b>		
26	SCREW M4 x 25	4	A1	SCREW M4 x 10	2
27	SPINDLE LOCK BUTTON	1	A2	GUARD	1
28	COIL SPRING $\phi 0.9 \times \phi 10 \times \phi 11.8 \times 13.5L \times 4T$	1	A3	GUARD BRACKET	1
29	SPINDLE LOCK	1	A4	4" SANDING PAD 4"	1

## 5" Wet-Dry model Stone Grinders Parts List (1200W)

NO.	Parts Name	Q'TY	NO.	Parts Name	Q'TY
1A	N/A	-	40	THUMB WHEEL	1
1B	POWER SUPPLY CABLE	1	41	GASKET	1
2	CORD ARMOR	1	42	SPRING WASHER M4	4
3	SCREW M4 x 16	2	43	EXTERNAL CIRCLIP S-12	1
4	ELECTRONICS BOARD	1	44	FAN BAFFLE	1
5	CABLE CLIP	1	45	OIL SEAL ø20 x ø30 x 5	2
6.	TAIL COVER	1	46	WATER FEED COLLAR	1
7	SCREW M4 x 10	4	47	N/A	-
8	SPIRAL TORSION SPRING	2	48	HOSE BRACKET	1
9	CARBON BRUSH 7 x 11 + 33L + FLDNBI-110	2	49	SCREW M5 x 6	1
10	CARBON BRUSH HOLDER	2	50	WATER FEED CONNECTOR KIT	1
11	SWITCH	1	51	WATER COUPLING	1
12	SWITCH SLIDER	1	52	L-HEX KEY M2	1
13	SWITCH LEVER	1	53~54	N/A	-
14	MOTOR HOUSING	1	55	HANDLE	1
15	STATOR	1	56	SOCKET CAP SCREW M8 x 16	2
16	STATOR SCREW M4 x 60	2	57	PRCD INTERRUPTER PROTECTION 110V	1
17	SCREW M4 x 10	1	57	PRCD INTERRUPTER PROTECTION 220V	1
18	FLAT WASHER ø4 x ø10 x 1	1	58	EARTH WIRE 20# 25cm + 4R x 10	1
19	PLASTIC WASHER ø4 x ø11 x 1	1	59	SCREW M4 x 6	1
20	PICKUP MAGNET ø8 x ø15 x 5	1	60	END SPLICE TERMINAL C4	1
21	SPACER ø8 x ø12 x 10.5	1	61~64	N/A	-
22	BEARING 608-2RU	1	65	WATER FEED COLLAR	1
23B	ARMATURE-LOW SPEED M1.15 x 6T (LOW SPEED)	1	66	SET SCREW M4 x 4	3
24	BEARING 6001-LLU	1	67~70	N/A	-
25	GEAR CASE	1	71	NIPPLE FITTING	1
26	SCREW M4 x 25	5	72	SCREW M4 x 14	6
27	SPINDLE LOCK BUTTON	1	73	RUBBER SLEEVE	1
28	COIL SPRING ø0.9 x ø10 x ø11.8 x 13.5L x 4T	1	74	SCREW M4 x 30	1
29	SPINDLE LOCK	1	75	INNER FLANGE	1
30	NEEDLE BEARING HK 0810	1	76	OUTER FLANGE	1
31B	BEVEL GEAR-LOW SPEED M1.15 x 43T (LOW SPEED)	1	77	LOCK NUT WRENCH	1
32	INTERNAL CIRCLIP R-35	1	<b>(Optional for 5" Wet-Dry model &amp; 5" Dust Collector Cover Model)</b>		
33	EXTERNAL CIRCLIP S-15	1	B1	INNER FLANGE	1
34	BEARING 6202-2RS	1	B2	OUTER FLANGE	1
35	PARALLEL KEY 3 x 3 x 8	1	B3	LOCK NUT WRENCH	1
36B	SPINDLE M14	1	B4	ALUMINUM CUP WHEEL M14	1
37	GEAR PLATE	1	B4	ALUMINUM CUP WHEEL 5/8"	1
38	SCREW M4 x 16	4	B5	FACE SPANNER WRENCH	1
39	N/A	-			

## 5" Dust Collector Cover Model Grinders Parts List (1200W)

NO.	Parts Name	QTY	NO.	Parts Name	Q'TY
1A	N/A	-	37	GEAR PLATE	1
1B	POWER SUPPLY CABLE	1	38	SCREW M4 x 16	4
2	CORD ARMOR	1	39	N/A	-
3	SCREW M4 x 16	2	40	THUMB WHEEL	1
4	ELECTRONICS BOARD	1	41	GASKET	1
5	CABLE CLIP	1	42	SPRING WASHER M4	4
6	TAIL COVER	1	43	EXTERNAL CIRCLIP S-12	1
7	SCREW M4 x 10	4	44	FAN SHROUD	1
8	SPIRAL TORSION SPRING	2	45	OIL SEAL $\phi 20 \times \phi 30 \times 5$	2
9	CARBON BRUSH 7 x 11 + 33L + FLDNBI-110	2	46~47	N/A	-
10	CARBON BRUSH HOLDER	2	48	HOSE BRACKET	1
11	SWITCH	1	49	SCREW M5 x 6	1
12	SWITCH SLIDER	1	50	WATER FEED CONNECTOR KIT	1
13	SWITCH LEVER	1	51	WATER COUPLING	1
14	MOTOR HOUSING	1	52	L-HEX KEY M2	1
15.	STATOR	1	53~54	N/A	-
16	STATOR SCREW M4 x 60	2	55	HANDLE	1
17	SCREW M4 x 10	1	56	SCREW M8 x 16	2
18	FLAT WASHER $\phi 4 \times \phi 10 \times 1$	1	57	PRCD INTERRUPTER PROTECTION	1
19.	PLASTIC WASHER $\phi 4 \times \phi 11 \times 1$	1	58	EARTH WIRE 20# 25cm + 4R x 10	1
20	PICKUP MAGNET $\phi 8 \times \phi 15 \times 5$	1	59	SCREW M4 x 6	1
21	SPACER $\phi 8 \times \phi 12 \times 10.5$	1	60	END SPLICE TERMINAL C4	1
22	BEARING 608-2RU	1	61~64	N/A	-
23B	ARMATURE-LOW SPEED M1.15 x 6T (LOW SPEED)	1	65	WATER FEED COLLAR	1
24	BEARING 6001-LLU	1	66	SET SCREW M4 x 4	2
25	GEAR CASE	1	67	SPRING $\phi 0.8 \times \phi 6.1 \times \phi 7.7 \times 8T \times 20L$	4
26	SCREW M4 x 25	5	68	SANDING PLATE COVER	1
27	SPINDLE LOCK BUTTON	1	69	HALF-MOON DOOR	1
28	COIL SPRING $\phi 0.9 \times \phi 10 \times \phi 11.8 \times 13.5L \times 4T$	1	70	INTERNAL CIRCLIP S-45	1
29	SPINDLE LOCK	1	71	NIPPLE FITTING	1
30	NEEDLE BEARING HK 0810	1	72	SCREW M4 x 14	6
31B	BEVEL GEAR-LOW SPEED M1.15 x 43T (LOW SPEED)	1	73	RUBBER SLEEVE	1
32	INTERNAL CIRCLIP R-35	1	74	SCREW M4 x 30	1
33	EXTERNAL CIRCLIP S-15	1	75	INNER FLANGE	1
34	BEARING 6202-2RS	1	76	OUTER FLANGE	1
35	PARALLEL KEY 3 x 3 x 8	1	77	OCK NUT WRENCH	1
36B	SPINDLE M14	1			

# 5" Stone Grinders Exploded View(700W)

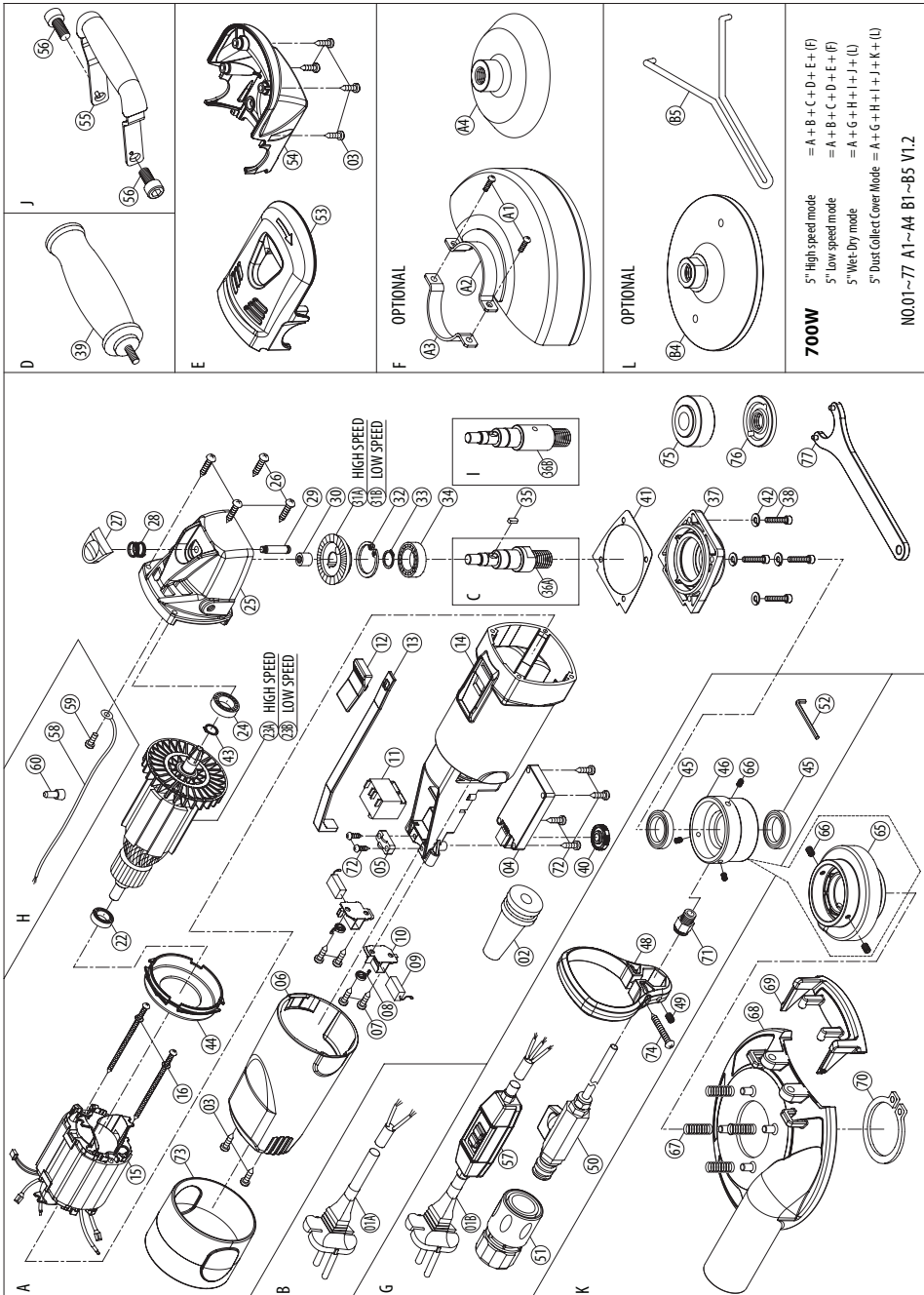



## 5" High speed model Stone Grinders Parts List (700W)

NO.	Parts Name	Q'TY	NO.	Parts Name	Q'TY
1A.	POWER SUPPLY CABLE	1	32	INTERNAL CIRCLIP R-35	1
1B	N/A	-	33	EXTERNAL CIRCLIP S-15	1
2	CORD ARMOR	1	34	BEARING 6202-2RS	1
3	SCREW M4 x 16	6	35	PARALLEL KEY 3 x 3 x 8	1
4	ELECTRONICS BOARD 700W	1	36A	SPINDLE M14	1
5	CABLE CLIP	1	36B	N/A	-
6	TAIL COVER	1	37	GEAR PLATE	1
7	SCREW M4 x 10	4	38	SCREW M4 x 16	4
8	SPIRAL TORSION SPRING	2	39	SIDE HANDLE	1
9	CARBON BRUSH 7 x 11 + 33L + FLDNBI-110	2	40	THUMB WHEEL	1
10	CARBON BRUSH HOLDER	2	41	GASKET	1
11	SWITCH	1	42	SPRING WASHER M4	4
12	SWITCH SLIDER	1	43	EXTERNAL CIRCLIP S-12	1
13	SWITCH LEVER	1	44	FAN SHROUD	1
14	MOTOR HOUSING	1	45~52	N/A	-
15	STATOR	1	53	GEARBOX COVER - UPPER	1
16	STATOR SCREW M4 x 60	2	54	GEARBOX COVER - LOWER	1
17~21	N/A	-	55~71	N/A	-
22	BEARING 608-2RU	1	72	SCREW M4 x 14	6
23A	ARMATURE-HIGH SPEED M1.2 x 8T (HIGH SPEED)	1	73	RUBBER SLEEVE	1
23B	N/A	-	74	N/A	1
24	BEARING 6001-LLU	1	75	INNER FLANGE	1
25	GEAR CASE	1	76	OUTER FLANGE	1
26	SCREW M4 x 25	4	77	LOCK NUT WRENCH	1
27	SPINDLE LOCK BUTTON	1		<b>Optional</b>	
28	COIL SPRING $\emptyset 0.9 \times \emptyset 10 \times \emptyset 11.8 \times 13.5L \times 4T$	1	A1	SCREW M4 x 10	2
29	SPINDLE LOCK	1	A2	GUARD	1
30	NEEDLE BEARING HK 0810	1	A3	GUARD BRACKET	1
31A	BEVEL GEAR-HIGH SPEED M1.2 x 33T (HIGH SPEED)	1	A4	4" SANDING PAD 4"	1
31B	N/A	-			

## 5" Low speed model Stone Grinders Parts List (700W)

NO.	Parts Name	Q'TY	NO.	Parts Name	Q'TY
1A	POWER SUPPLY CABLE	1	32	INTERNAL CIRCLIP R-35	1
1B	N/A	-	33	EXTERNAL CIRCLIP S-15	1
2	CORD ARMOR	1	34	BEARING 6202-2RS	1
3	SCREW M4 x 16	6	35	PARALLEL KEY 3 x 3 x 8	1
4	ELECTRONICS BOARD 700W	1	36A	SPINDLE M14	1
5	CABLE CLIP	1	36B	N/A	-
6	TAIL COVER	1	37	GEAR PLATE	1
7	SCREW M4 x 10	4	38	SCREW M4 x 16	4
8	SPIRAL TORSION SPRING	2	39	SIDE HANDLE	1
9	CARBON BRUSH 7 x 11 + 33L + FLDNBI-110	2	40	THUMB WHEEL	1
10	CARBON BRUSH HOLDER	2	41	GASKET	1
11	SWITCH	1	42	SPRING WASHER M4	4
12	SWITCH SLIDER	1	43	EXTERNAL CIRCLIP S-12	1
13	SWITCH LEVER	1	44	FAN BAFFLE	1
14	MOTOR HOUSING	1	45~52	N/A	-
15	STATOR	1	53	GEARBOX COVER - UPPER	1
16	STATOR SCREW M4 x 60	2	54	GEARBOX COVER - LOWER	1
17~21	N/A	-	55~71	N/A	-
22	BEARING 608-2RU	1	72	SCREW M4 x 14	6
23A	N/A	-	73	RUBBER SLEEVE	1
23B	ARMATURE-LOW SPEED M1.15 x 6T (LOW SPEED)	1	74	N/A	-
24	BEARING 6001-LLU	1	75	INNER FLANGE	1
25	GEAR CASE	1	76	OUTER FLANGE	1
26	SCREW M4 x 25	4	77	LOCK NUT WRENCH	1
27	SPINDLE LOCK BUTTON	1	<b>Optional</b>		
28	COIL SPRING $\varnothing 0.9 \times \varnothing 10 \times \varnothing 11.8 \times 13.5L \times 4T$	1	A1	SCREW M4 x 10	2
29	SPINDLE LOCK	1	A2	GUARD	1
30	NEEDLE BEARING HK 0810	1	A3	GUARD BRACKET	1
31A	N/A	-	A4	4" SANDING PAD 4"	1
31B	BEVEL GEAR-LOW SPEED M1.15 x 43T (LOW SPEED)	1			

## 5" Wet-Dry model Stone Grinders Parts List (700W)

NO.	Parts Name	QTY	NO.	Parts Name	Q'TY
1A	N/A	-	40	THUMB WHEEL	1
1B	POWER SUPPLY CABLE	1	41	GASKET	1
2	CORD ARMOR	1	42	SPRING WASHER M4	4
3	SCREW M4 x 16	2	43	EXTERNAL CIRCLIP S-12	1
4	ELECTRONICS BOARD 700W	1	44	FAN BAFFLE	1
5	CABLE CLIP	1	45	OIL SEAL Ø20 x Ø30 x 5	2
6	TAIL COVER	1	46	WATER FEED COLLAR	1
7	SCREW M4 x 10	4	47	N/A	-
8	SPIRAL TORSION SPRING	2	48	HOSE BRACKET	1
9	CARBON BRUSH 7 x 11 + 33L + FLDNBI-110	2	49	SCREW M5 x 6	1
10	CARBON BRUSH HOLDER	2	50	WATER FEED CONNECTOR KIT	1
11	SWITCH	1	51	WATER COUPLING	1
12	SWITCH SLIDER	1	52	L-HEX KEY M2	1
13	SWITCH LEVER	1	53~54	N/A	-
14	MOTOR HOUSING	1	55	HANDLE	1
15	STATOR	1	56	SOCKET CAP SCREW M8 x 16	2
16~21	N/A	-	57	PRCD INTERRUPTER PROTECTION	1
22	BEARING 608-2RU	1	58	EARTH WIRE 20# 25cm + 4R x 10	1
23A	N/A	-	59	SCREW M4 x 6	1
23B	ARMATURE-LOW SPEED M1.15 x 6T (LOW SPEED)	1	60	END SPLICE TERMINAL C4	1
24	BEARING 6001-LLU	1	61~64	N/A	-
25	GEAR CASE	1	65	WATER FEED COLLAR	1
26	SCREW M4 x 25	4	66	SET SCREW M4 x 4	3
27	SPINDLE LOCK BUTTON	1	67~70	N/A	-
28	COIL SPRING Ø0.9 x Ø10 x Ø11.8 x 13.5L x 4T	1	71	NIPPLE FITTING	1
29	SPINDLE LOCK	1	72	SCREW M4 x 14	6
30	NEEDLE BEARING HK 0810	1	73	RUBBER SLEEVE	1
31A	N/A	-	74	SCREW M4 x 30	1
31B	BEVEL GEAR-LOW SPEED M1.15 x 43T (LOW SPEED)	1	75	INNER FLANGE	1
32	INTERNAL CIRCLIP R-35	1	76	OUTER FLANGE	1
33	EXTERNAL CIRCLIP S-15	1	77	LOCK NUT WRENCH	1
34	BEARING 6202-2RS	1	<b>Optional</b>		
35	PARALLEL KEY 3 x 3 x 8	1	B1	INNER FLANGE	1
36A	N/A	-	B2	OUTER FLANGE	1
36B	SPINDLE M14	1	B3	LOCK NUT WRENCH	1
37	GEAR PLATE	1	B4	ALUMINUM CUP WHEEL M14	1
38	SCREW M4 x 16	4	B5	ALUMINUM CUP WHEEL 5/8"	1
39	N/A	-	B6	FACE SPANNER WRENCH	1

## 5" Dust Collector Cover Model Grinders Parts List (700W)

NO.	Parts Name	Q'TY	NO.	Parts Name	Q'TY
1A	N/A	-	41	GASKET	1
1B	POWER SUPPLY CABLE	1	42	SPRING WASHER M4	4
2	CORD ARMOR	1	43	EXTERNAL CIRCLIP S-12	1
3	SCREW M4 x 16	2	44	FAN SHROUD	1
4	ELECTRONICS BOARD (700W)	1	45	OIL SEAL Ø20 x Ø30 x 5	2
5	CABLE CLIP	1	46~47	N/A	-
6	TAIL COVER	1	48	HOSE BRACKET	1
7	SCREW M4 x 10	4	49	SCREW M5 x 6	1
8	SPIRAL TORSION SPRING	2	50	WATER FEED CONNECTOR KIT	1
9	CARBON BRUSH 7 x 11 + 33L + FLDNBI-110	2	51	WATER COUPLING	1
10	CARBON BRUSH HOLDER	2	52	L-HEX KEY M2	1
11	SWITCH	1	53~54	N/A	-
12	SWITCH SLIDER	1	55	HANDLE	1
13	SWITCH LEVER	1	56	SCREW M8 x 16	2
14	MOTOR HOUSING	1	57	PRCD INTERRUPTER PROTECTION	1
15	STATOR	1	58	EARTH WIRE 20# 25cm + 4R x 10	1
16~21	N/A	-	59	SCREW M4 x 6	1
22	BEARING 608-2RU	1	60	END SPLICE TERMINAL C4	1
23A	N/A	-	61~64	N/A	-
23B	ARMATURE-LOW SPEED M1.15 x 6T (LOW SPEED)	1	65	WATER FEED COLLAR	1
24	BEARING 6001-2RS	1	66	SET SCREW M4 x 4	2
25	GEAR CASE	1	67	SPRING Ø0.8 x Ø6.1 x Ø7.7 x 8T x 20L	4
26	SCREW M4 x 25	4	68	SANDING PLATE COVER	1
27	SPINDLE LOCK BUTTON	1	69	HALF-MOON DOOR	1
28	COIL SPRING Ø0.9 x Ø10 x Ø11.8 x 13.5L x 4T	1	70	INTERNAL CIRCLIP S-45	1
29	SPINDLE LOCK	1	71	NIPPLE FITTING	1
30	NEEDLE BEARING HK 0810	1	72	SCREW M4 x 14	6
31A	N/A	-	73	RUBBER SLEEVE	1
31B	BEVEL GEAR-LOW SPEED M1.15 x 43T (LOW SPEED)	1	74	SCREW M4 x 30	1
32	INTERNAL CIRCLIP R-35	1	75	INNER FLANGE	1
33	EXTERNAL CIRCLIP S-15	1	76	OUTER FLANGE	1
34	BEARING 6202-2RS	1	77	LOCK NUT WRENCH	1
35	PARALLEL KEY 3 x 3 x 8	1	<b>Optional</b>		
36A	N/A	-	B1	INNER FLANGE	1
36B	SPINDLE M14	1	B2	OUTER FLANGE	1
37	GEAR PLATE	1	B3	LOCK NUT WRENCH	1
38	SCREW M4 x 16	4	B4	ALUMINUM CUP WHEEL M14	1
39	N/A	-	B5	ALUMINUM CUP WHEEL 5/8"	1
40	THUMB WHEEL	1	B6	FACE SPANNER WRENCH	1

# 7" Stone Grinders Exploded View

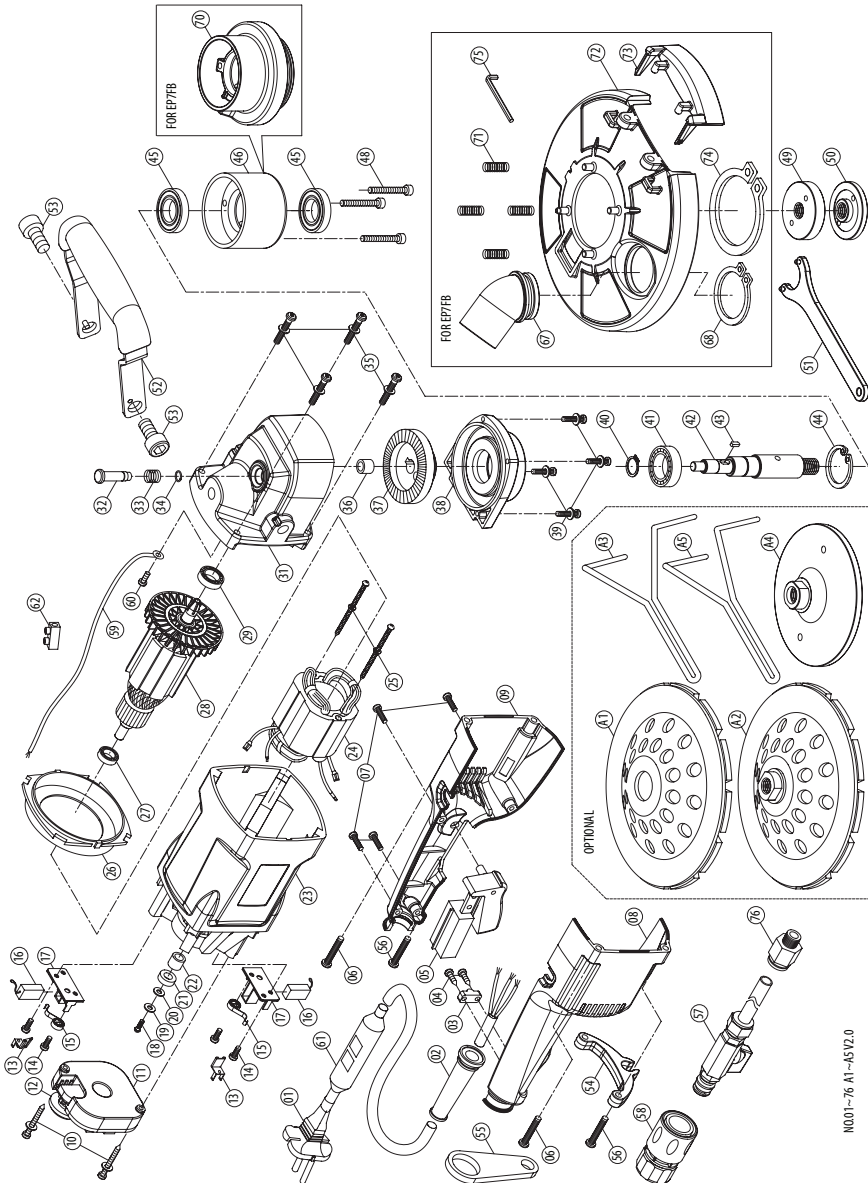

N001-76 A1-A5V2.0

## 7" Wet-Dry model Stone Grinders Parts List

NO.	Parts Name	Q'TY	NO.	Parts Name	Q'TY
1	POWER SUPPLY CABLE	1	40	EXTERNAL CIRCLIP S-17	1
2	CORD ARMOR	1	41	BALL BEARING 6203-2RS	1
3	CABLE CLIP	1	42	SPINDLE M14xP2.0-130.7mm	1
4	SCREW M4 x 14	2	42	SPINDLE 5/8"-11-130.7mm	1
5	SWITCH	1	43	PARALLEL KEY 5 x 5 x 12	1
6	SCREW M5 x 30	2	44	INTERNAL CIRCLIP R-40	1
7	SCREW M4 x 16	4	45	OIL SEAL Ø20 x Ø38 x 7	2
8	RIGHT HANDLE COVER	1	46	WATER FEED COLLAR	1
9	LEFT HANDLE COVER	1	47	N/A	-
10	SCREW M4 x 30	2	48	SCREW M5 x 35	3
11	ELECTRONICS UNIT	1	49	INNER FLANGE M14	1
11	ELECTRONICS UNIT	1	49	INNER FLANGE 5/8"	1
12	THUMB WHEEL	1	50	ARBOR NUT M14/22.2mm	1
13	3-WAY CONNECTOR	2	50	ARBOR NUT M14/25.4mm	1
14	SCREW M4 x 10	4	50	ARBOR NUT 5/8"/22.2mm	1
15	BRUSH SPRING	2	50	ARBOR NUT 5/8"/25.4mm	1
16	CARBON BRUSH 7 x 17+ 250	2	51	LOCK NUT WRENCH	1
17	CARBON BRUSH HOLDER 7 x 17	2	52	FRONT HANDLE	1
18	SCREW M4 x 10	1	53	SCREW M12 x 16	2
19	FLAT WASHER Ø4 x Ø10 x 1	1	54	HOSE BRACKET	1
20	PLASTIC WASHER Ø4 x Ø11 x 1	1	55	HOSE RUBBER SUPPORT	1
21	PICKUP MAGNET Ø8 x Ø15 x 5	1	56	SCREW M5 x 35	2
22	SPACER Ø8 x Ø12 x 10.5	1	57	WATER FEED CONNECTOR KIT	1
23	MOTOR HOUSING	1	58	WATER COUPLING	1
24	STATOR	1	59	EARTH WIRE 20# 35cm + 4R x 10	1
25	SCREW M5 x 60	2	60	SCREW M4 x 8	1
26	FAN BAFFLE	1	61	PRCD INTERRUPTER PROTECTION 110V	1
27	BALL BEARING 6200 zz	1	61	PRCD INTERRUPTER PROTECTION 220V	1
28	ARMATURE M1.25 x 6T	1	62	BLOCK CONNECTOR	1/12
29	BALL BEARING 6201-2RS	1	63~75	N/A	-
30	N/A	-	76	NIPPLE FITTING	1
31	GEAR CASE	1			
32	SPINDLE LOCK	1	<b>BELOW ARE OPTIONAL</b>		
33	SPRING Ø0.8 x Ø8.5 x Ø10.1 x 20L x 6T	1	A1	DIAMOND PLATE (B)	1
34	C-CLIP Ø0.6 x Ø7.4 x Ø8.6	1	A2	DIAMOND PLATE (B)	1
35	SCREW M5 x 30	4	A3	FACE SPANNER WRENCH	1
36	NEEDLE BEARING TLA 0810	1	A4	ALUMINUM PAD M14	1
37	BEVEL GEAR M1.25 x 55T	1	A4	ALUMINUM PAD 5/8"	1
38	GEAR PLATE	1	A5	FACE SPANNER WRENCH	1
39	SCREW M4 x 25	4			

## 7" Dust Collector Cover Model Stone Grinders Parts List

NO.	Parts Name	Q'TY	NO.	Parts Name	Q'TY
1	POWER SUPPLY CABLE	1	43	PARALLEL KEY 5 x 5 x 12	1
2	CORD ARMOR	1	44	INTERNAL CIRCLIP R-40	1
3	CABLE CLIP	1	45	OIL SEAL Ø20 x Ø38 x 7	2
4	SCREW M4 x 14	2	46~47	N/A	-
5	SWITCH	1	48	SCREW M5 x 35	3
6	SCREW M5 x 30	2	49	INNER FLANGE M14	1
7	SCREW M4 x 16	4	49	INNER FLANGE 5/8"	1
8	RIGHT HANDLE COVER	1	50	ARBOR NUT M14/22.2mm	1
9	LEFT HANDLE COVER	1	50	ARBOR NUT M14/25.4mm	1
10	SCREW M4 x 30	2	50	ARBOR NUT 5/8"/22.2mm	1
11	ELECTRONICS UNIT	1	50	ARBOR NUT 5/8"/25.4mm	1
12	THUMB WHEEL	1	51	LOCK NUT WRENCH	1
13	3-WAY CONNECTOR	2	52	FRONT HANDLE	1
14	SCREW M4 x 10	4	53	SCREW M12 x 16	2
15	BRUSH SPRING	2	54	HOSE BRACKET	1
16	CARBON BRUSH 7 x 17+ 250	2	55	HOSE RUBBER SUPPORT	1
17	CARBON BRUSH HOLDER 7 x 17	2	56	SCREW M5 x 35	2
18	SCREW M4 x 10	1	57	WATER FEED CONNECTOR KIT	1
19	FLAT WASHER Ø4 x Ø10 x 1	1	58	WATER COUPLING	1
20	PLASTIC WASHER Ø4 x Ø11 x 1	1	59	EARTH WIRE 20# 35cm + 4R x 10	1
21	PICKUP MAGNET Ø8 x Ø15 x 5	1	60	SCREW M4 x 8	1
22	SPACER Ø8 x Ø12 x 10.5	1	61	PRCD INTERRUPTER PROTECTION 110V	1
23	MOTOR HOUSING	1	61	PRCD INTERRUPTER PROTECTION 220V	1
24	STATOR	1	62	BLOCK CONNECTOR	1/12
25	SCREW M5 x 60	2	63~66	N/A	-
26	FAN BAFFLE	1	67	DUST ATTACHMENT	1
27	BALL BEARING 6200 zz	1	68	EXTERNAL CIRCLIP S-40	1
28	ARMATURE M1.25 x 6T	1	69	N/A	-
29	BALL BEARING 6201-2RS	1	70	WATER FEED COLLAR	1
30	N/A	-	71	SPRING Ø0.8xØ6.1xØ7.7x8Tx20L	4
31	GEAR CASE	1	72	SANDING PLATE COVER	1
32	SPINDLE LOCK	1	73	HALF-MOON DOOR	1
33	SPRING Ø0.8 x Ø8.5 x Ø10.1 x 20L x 6T	1	74	EXTERNAL CIRCLIP S-65	1
34	C-CLIP Ø0.6 x Ø7.4 x Ø8.6	1	75	L-HEX KEY M4	1
35	SCREW M5 x 30	4	76	NIPPLE FITTING	1
36	NEEDLE BEARING TLA 0810	1			
37	BEVEL GEAR M1.25 x 55T	1		<b>BELOW ARE OPTIONAL</b>	
38	GEAR PLATE	1	A1	DIAMOND PLATE (B)	1
39	SCREW M4 x 25	4	A2	DIAMOND PLATE (B)	1
40	EXTERNAL CIRCLIP S-17	1	A3	FACE SPANNER WRENCH	1
41	BALL BEARING 6203-2RS	1	A4	ALUMINUM PAD M14	1
42	SPINDLE M14xP2.0-130.7mm	1	A4	ALUMINUM PAD 5/8"	1
42	SPINDLE 5/8"-11-130.7mm	1	A5	FACE SPANNER WRENCH	1

